

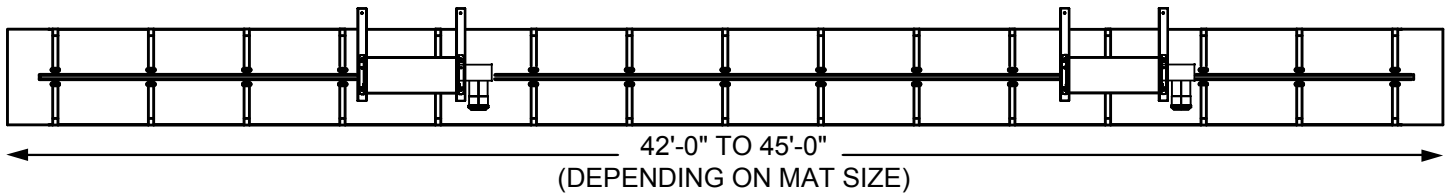

MHWM-D-A WALL MOUNTED DOUBLE MAT HOIST

TOP VIEW - ORIENTATION PARALLEL TO WALL



SIDE VIEW

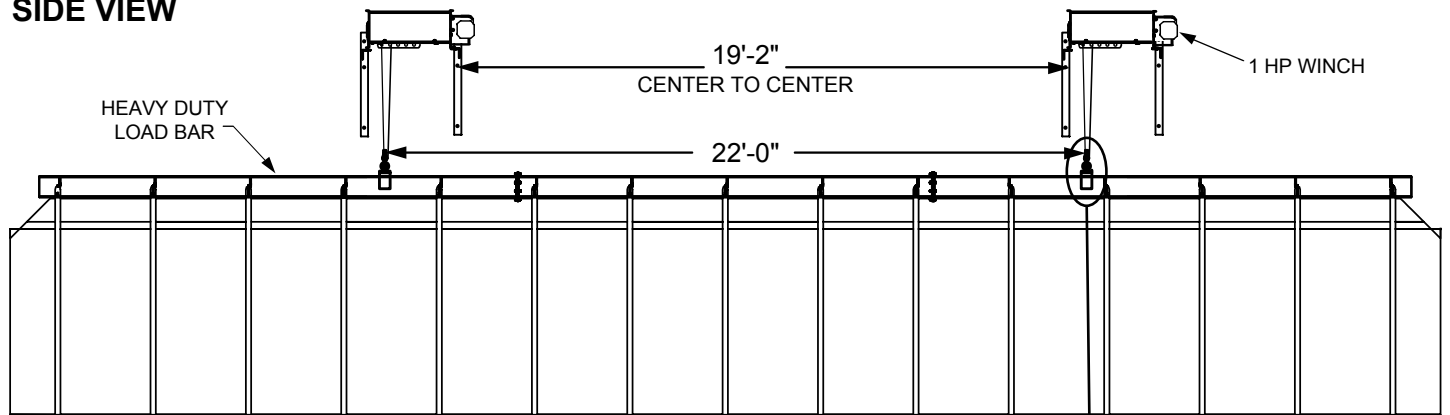

REQUIRED INFORMATION:

1. POWER REQUIREMENTS:

- 208-240VAC - 3 Phase (STANDARD)
- 120VAC - 1 Phase*
- 208-240VAC - 1 Phase*
- 400-480VAC - 3 Phase*
- 600VAC - 3 Phase*

* May incur additional cost and lead time

2. ELEVATION OF STRUCTURE: (From finished floor)

3. MAT SIZES / QUANTITIES:

- 14' X 42' QTY: _____
- 42' X 42' QTY: _____
- 45' X 45' QTY: _____
- Other: _____

Maximum is 2025 ft² (At assumed 1 lb/ft²)

Rollled Mat Diameter: _____

Assumed 36" if not otherwise specified

4. SLING COLOR:

- Red
- Yellow
- Orange*
- Black
- Gray
- Light Blue
- Blue
- Green
- Brown*

*Some colors may incur additional cost

5. OPTIONAL EQUIPMENT:

- ML-2000 MatLok Safety Strap
2 MatLoks required per system

NOTE: STRUCTURAL SUPPORTS MUST BE DESIGNED BY ARCHITECT OR STRUCTURAL ENGINEER. STRUCTURE IS SUPPLIED BY OTHERS (NOT JAYPRO) AND MUST BE CAPABLE OF SUPPORTING SPECIFIED LOADS (SEE SYSTEM WEIGHT TABLE).

END VIEW

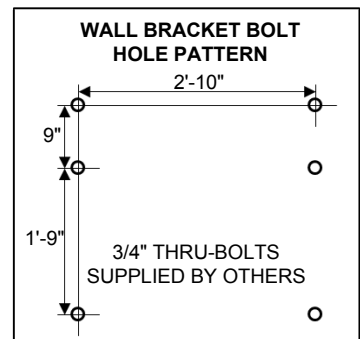
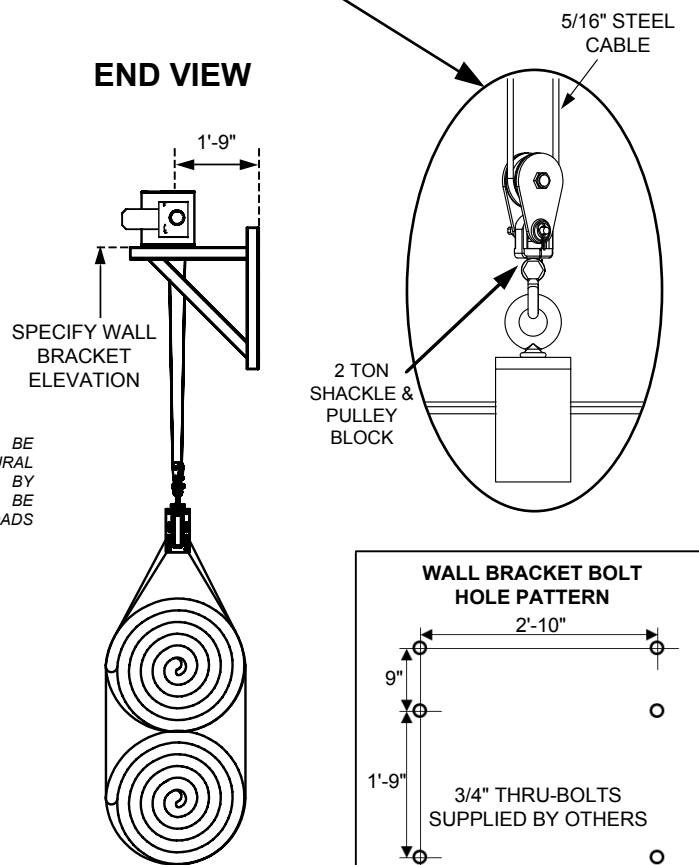

PROJECT NAME _____

PROJECT NUMBER _____

ARCHITECT _____

CONTRACTOR _____

NOTES _____



MHWM-D-A
DOUBLE MAT HOIST, WALL MOUNTED

© COPYRIGHT 2014 JAYPRO SPORTS, LLC. ALL RIGHTS RESERVED
THIS PRINT IS THE PROPERTY OF JAYPRO SPORTS, LLC. AND MAY
NOT BE REPRODUCED WITHOUT WRITTEN PERMISSION

www.jaypro.com
(800) 243-0533
976 Hartford Turnpike
Waterford, CT 06385 USA

Sheet 1 of 2



Jaypro SecureLift™ Mat Storage System Wall Mounted Double Wrestling Mat Hoist

Stationary system, wall mounted structure supported. Synchronized mat lifting system for storage, raising and lowering of two (2) 42' x 42' or 45' x 45' wrestling mat.

MAT STORAGE SYSTEM WEIGHT	
WINCHES / ATTACHMENTS / WALL MOUNTS	650 LBS
LOAD BAR	550 LBS
DOUBLE SLING & STRAPS	160 LBS
2x MAT (45' x 45' @ 1 LB / FT ²)	4050 LBS
15% LOAD SAFETY FACTOR	815 LBS
TOTAL SYSTEM WEIGHT	6225 LBS

GENERAL The dual hoist design consists of two (2) independent custom designed winches supported by four (4) heavy duty triangular wall brackets located 22'-0" on center. Wall must be capable of supporting entire load (as indicated in above table) as well as meet all applicable building codes. The structural adequacy of the wall is the responsibility of the Architect or Structural Engineer (Jaypro is not responsible). Wall brackets to be anchored to wall with twelve (12) 3/4" thru-bolts (supplied by others). All hoisting / lifting hardware and components are designed with a minimum of 5:1 factor of safety.

LOAD BAR The load bar is constructed of 2" x 8" heavy walled rectangular steel tube, 43' long. Bar has steel 'J' hooks welded at evenly spaced intervals. Bar is provided in three (3) sections that are spliced (bolted) together using eight (8) Grade 8 hardware. All load bar welds are by certified welders.

SLING Sling fabric to be 18 oz. solid vinyl coated polyester base material with sewn in straps. Strap material to be 2" wide, 3000 lb. breaking strength, located 3 feet on centers. Heavy duty 'D'-rings shall be sewn in at each strap end for attachment to load bar. Vinyl shall have fire retardant ratings to meet all requirements of NFPA 701 (Test Method 2), ASTM-E-84-Class A, and State of California test requirements. Color shall be as specified by owner.

WINCH Unit is powered by two (2) winches with synchronized motor controller. Each winch is mounted to existing support structure by way of four (4) 1/2" diameter high strength bolt and beam clamp assemblies (1300 lb min tensile strength per bolt). Winches raise and lower the load bar by means of two (2) 5/16", 7x19, steel cables (9800 lb. breaking load each). Mats are raised and lowered at a rate of no less than 5.5 feet per minute.

Each winch shall be driven by a 1 HP, instantly reversing, 208-240 volt* (3.7FLA), three phase electric brake motor. Each winch shall have a 1,900lb vertical lift capacity and be rated for continuous duty. Drum shall be grooved for a 5/16", 7x19 cable, and shall be supplied with a pressure cable roller, with torsion spring tensioning, to ensure that the cable 'tracks' in the drum grooves even under slack cable conditions. The winch shall be direct drive, with a fully enclosed single-stage worm gear reducer, and contain no 'V' belts or chains. It shall have a uni-directional worm brake, as well as a dynamic safety brake to provide positive dynamic braking and reliable holding of the cable drum. Each winch has an integral adjustable upper and lower travel limit switch.

* 208-240VAC standard. Other voltages available and may incur additional cost and lead time. See "Power Requirements" on Sheet 1.

WIRING Hoist system shall be supplied with a 3 position key switch which shall be located in clear view of the mat hoist to ensure unobstructed view during operation. Additional operators are available and must be specified at time of order or specification. Wiring of all electrical components shall be in accordance with national and local electrical codes, as well as specific wiring instructions provided by Jaypro. All wiring, conduit and miscellaneous electrical components (e.g. disconnects) shall be provided and installed by the electrical contractor. Winches may each have a dedicated circuit or share a single circuit. Control wiring to consist of two runs of Ethernet cable (one run from key switch to each winch).

CONTROL SYSTEM Jaypro's controller monitors and synchronizes the operation of both hoists. Vector speed control at each winch and a control board installed at the key switch ensures synchronous speed without the need for a separate control panel. Redundant upper limits are provided for added safety. The controller features a safety monitoring system that constantly verifies proper operation of each hoist, and shuts the entire system down in the event of a single winch failure. This safety feature protects against electrical, mechanical, and ambient environmental issues such as overvoltage, elevated temperatures, and a loss of mechanical load (i.e. cable failure) among many other modes of failure.

WARRANTY Jaypro SecureLift™ Mat Storage System comes with a 1 Year Limited Warranty. Other components may be covered under their own extended warranty.

OPTIONAL COMPONENTS

- MEC Pad Master Equipment Controller (Refer to MEC-99 Specification Sheet)
- ETEC Easy Touch Equipment Controller (Refer to ETEC Specification Sheet)
- MatLok™ Safety Strap (Refer to ML-2000 Specification Sheet)
- SecureLift™ Audible Alarm