

# PL-1000

## POSILOK™ BACKSTOP SAFETY STRAP

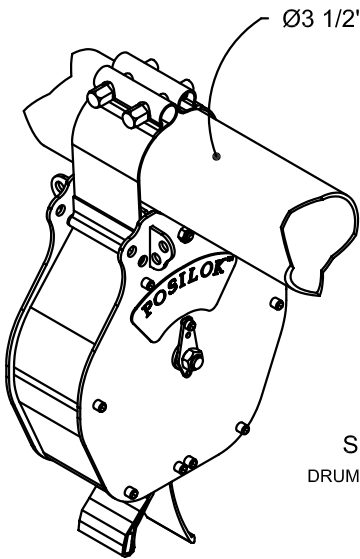

Ø3 1/2" PIPE

**FAIL-SAFE:**  
ARRESTING MECHANISM  
DEFAULTS TO LOCKED POSITION

**STRONGER CLAMPING  
SYSTEM:**  
TESTED TO 10,000 LBS

**SELF-CHECKING:**  
DRUM SPEED CHECKED 6x PER  
REVOLUTION

**POSITIVE RECOIL:**  
REEL SPRING IS 75%  
STRONGER THAN OTHER UNITS

**VERSATILE  
MOUNTING:**  
MULTIPLE HOLE PATTERN ALLOWS  
FOR FOUR MOUNTING POSITIONS

**FASTER CHECKING:**  
REACTION SPEEDS 4x FASTER  
THAN OTHER UNITS

**ROBUST STEEL FRAME**  
INTERLOCKING STEEL FRAME FAR  
EXCEEDS THE STRENGTH OF  
CAST STEEL

**TELLTALE INDICATOR:**  
VISUALLY SIGNALS UNIT HAS  
BEEN CALLED INTO ACTION

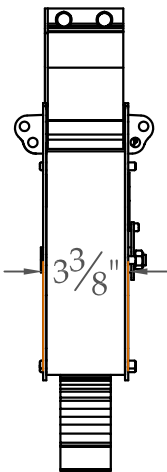

**SIDE VIEW**

**HEAVY DUTY STRAP:**  
7,300 LBS BREAKING STRENGTH

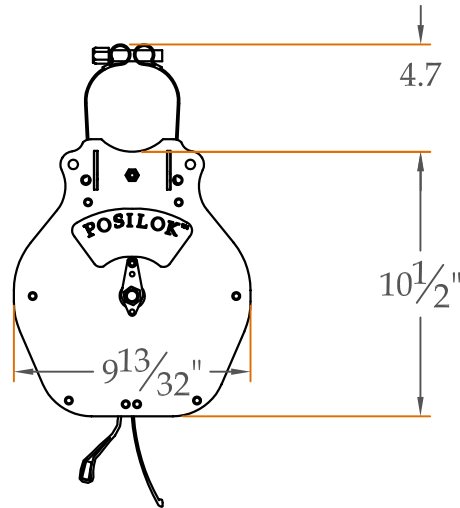

**FRONT VIEW**

REV.	DESCRIPTION	DATE	BY

**PL-1000  
POSILOK™  
BACKSTOP SAFETY STRAP**



www.jaypro.com

976 HARTFORD TURNPIKE  
WATERFORD, CT 06385 USA

**DRAWING NAME / PART NO.:**  
PL-1000

**DRAWN BY:** MT

**CHK'D BY:** DM

**ISSUE DATE:**  
3/3/05

**SHEET:**  
1 OF 1

**REV.**  
REV

COPYRIGHT 2003  
JAYPRO SPORTS, LLC.  
ALL RIGHTS RESERVED

THIS PRINT IS THE PROPERTY OF JAYPRO SPORTS, LLC.  
AND MAY NOT BE REPRODUCED WITHOUT WRITTEN PERMISSION

# JAYPRO MODEL PL-1000

## POSILOK™ BACKSTOP SAFETY BELT

The PL-1000 shall be directly speed sensitive to automatically lock a basketball backstop or divider curtain in position at any time in storage or during the raising or lowering cycle in the event of an over-speed created malfunction of the hoisting apparatus, such as a winch, cable, pulleys, support fittings, etc. Any increase in cycle speed or tension, whether sudden or gradual, immediately activates the locking device. The mechanism shall be made of high strength metal components and shall apply on both sides of the reel for balanced loading and greater sensitivity. The reel shall be supported on both sides by bearings to assure that there is no deflection under heavy load, which would cause the strap to misalign and suffer damage. The strap shall be automatically retracted and stored on a reel equipped with a special negator-type constant force spring. The mechanism shall incorporate a fully automatic reset requiring no poles, ropes, levers or buttons. The entire mechanism shall have an interlocking all-steel frame and be powder coated for corrosion resistance and a modern aesthetically-pleasing appearance.

The PL-1000 is provided with a universal mounting system to allow mounting orientations either parallel or perpendicular to the strap. Standard bracketry provides mounting to 3-1/2" OD support pipes or wide beam flange, sized 4" to 8" wide.

The PL-1000 shall incorporate a 2" wide, 40' long belt rated at 7,300 lbs. The maximum extension of the strap, 38', shall make visible a safety alert patch stitched to the strap to indicate the maximum safe extension. The entire unit shall be capable of supporting a falling weight of 1000# without strap failure or structural damage. The strap anchoring system shall bear on the full width of the strap and be capable of taking the full breaking strength of the strap.

The lower end of the strap shall have a "Telltale Indicator" to notify the customer when the safety belt has been called into action. The Telltale Indicator is a breakaway loop sewn into the lower strap containing a brightly colored warning label that shall be exposed should the stitching be torn out due to the proper catch of a falling load.

The locking mechanism must be fail safe, meaning that any sticking, jamming or breakage of any of the components of the arresting mechanism will result in immediate, positive locking of the reel. The locking mechanism shall react to the actual speed of the reel and prevent it from exceeding a strap speed of 1.5 feet per second regardless of whether the load suddenly drops by breakage of a component in the hoisting apparatus or whether it accelerates more slowly, caused by a back driving winch or the yielding of a structural component. The locking mechanism must be self-checking, meaning that during normal use the mechanism is in constant motion to prevent long-term binding or seizing caused by dirt or corrosion. The mechanism shall actively and positively confirm, six times per revolution that the reel is traveling at safe speed, below 1.5 feet per second. The action of the mechanism shall be audible to facilitate pre-installation checking and to prove positive operation of the mechanism.

The PL-1000 shall be warranted to be free of manufacturing defects for a period of 10 years