

TOOLS REQUIRED:
(2) 10mm WRENCHES

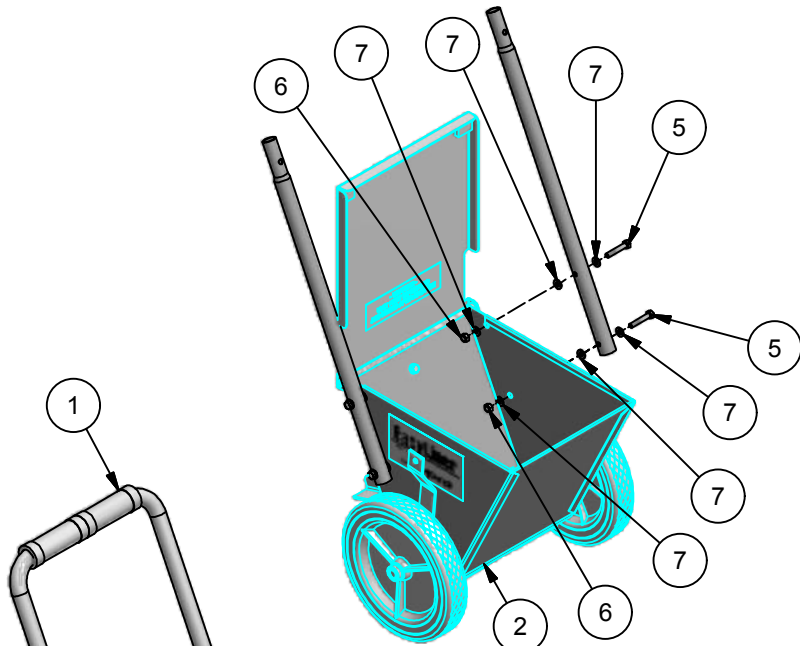

STEP 1
(ATTACH ARMS TO HOPPER)

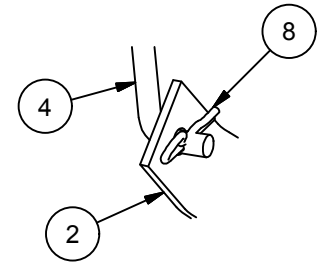

STEP 3
(BOTTOM END OF ROD)

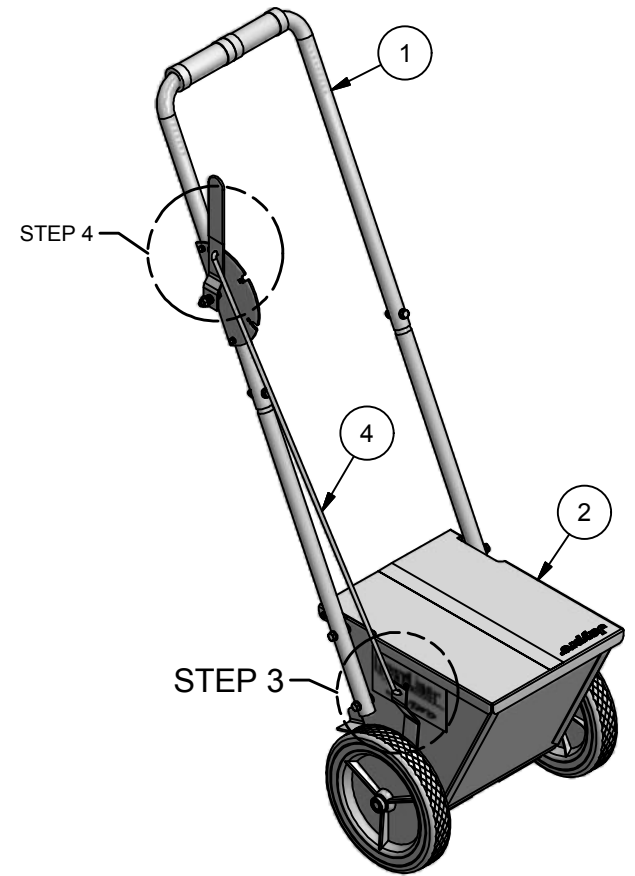

STEP 3

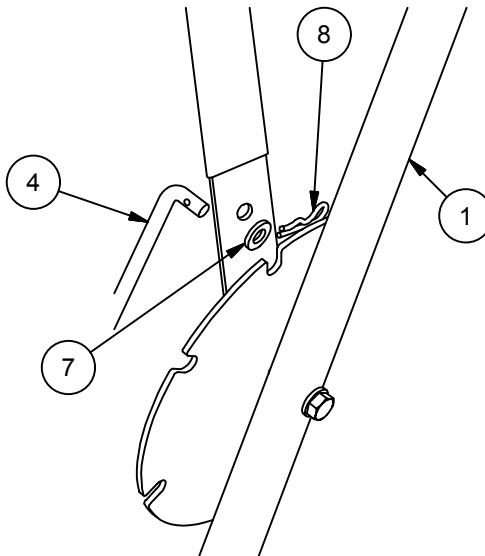

STEP 4
(UPPER END OF ROD)

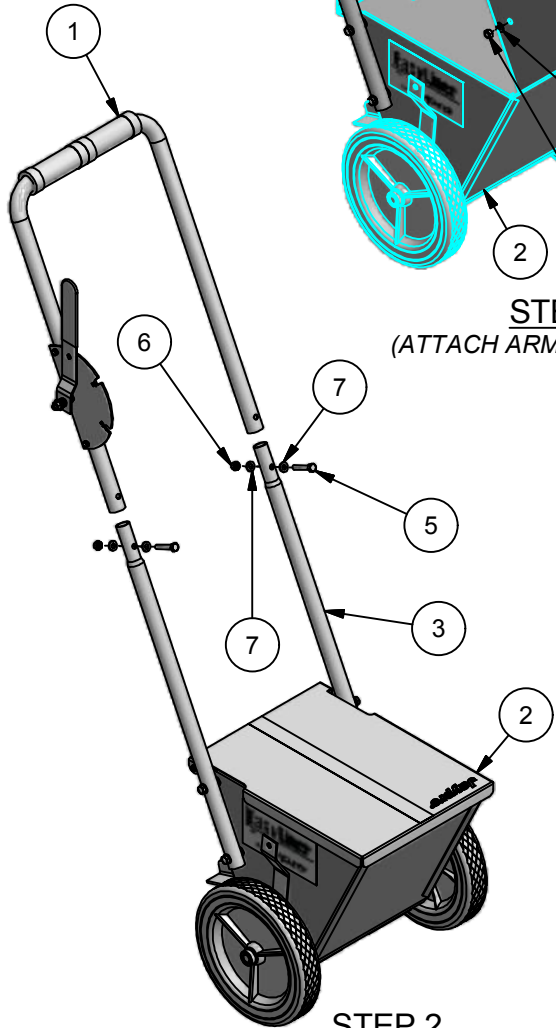

STEP 2
(ATTACH HANDLE TO ARMS)

ITEM	QTY	PART #	REV	DESCRIPTION
1	1	FM-25R-BK	A	HANDLE ASSEMBLY
2	1	FM-25R-FALT	A	HOPPER ASSEMBLY
3	2	FM25R-E1	-	25 LBS SUPPORT HANDLE
4	1	FM25R-H	A	25 LBS GATE CONTROL ROD
5	6	FM-0BC	N/A	M6 x 35 mm LONG HEX HD, SS
6	6	FM-0NB	N/A	M6 NYLON LOCK NUT, SS
7	17	FM-0WB	N/A	M6 FLAT WASHER, SS
8	2	FM-212	A	2 mm HAIRPIN COTTER PIN

 976 Hartford Turnpike Waterford, CT 06385 USA (800)243-0533 Fax: (800)988-3363 www.jaypro.com	MODEL NUMBER: FLMR-25		CHECKED BY: WVB	
	PRODUCT NAME: 25 LBS LINE DRY MARKER			
	DATE: 5/17/2012	REV: A	DRAWN BY: Moune T.	SHEET: 1 OF 1