

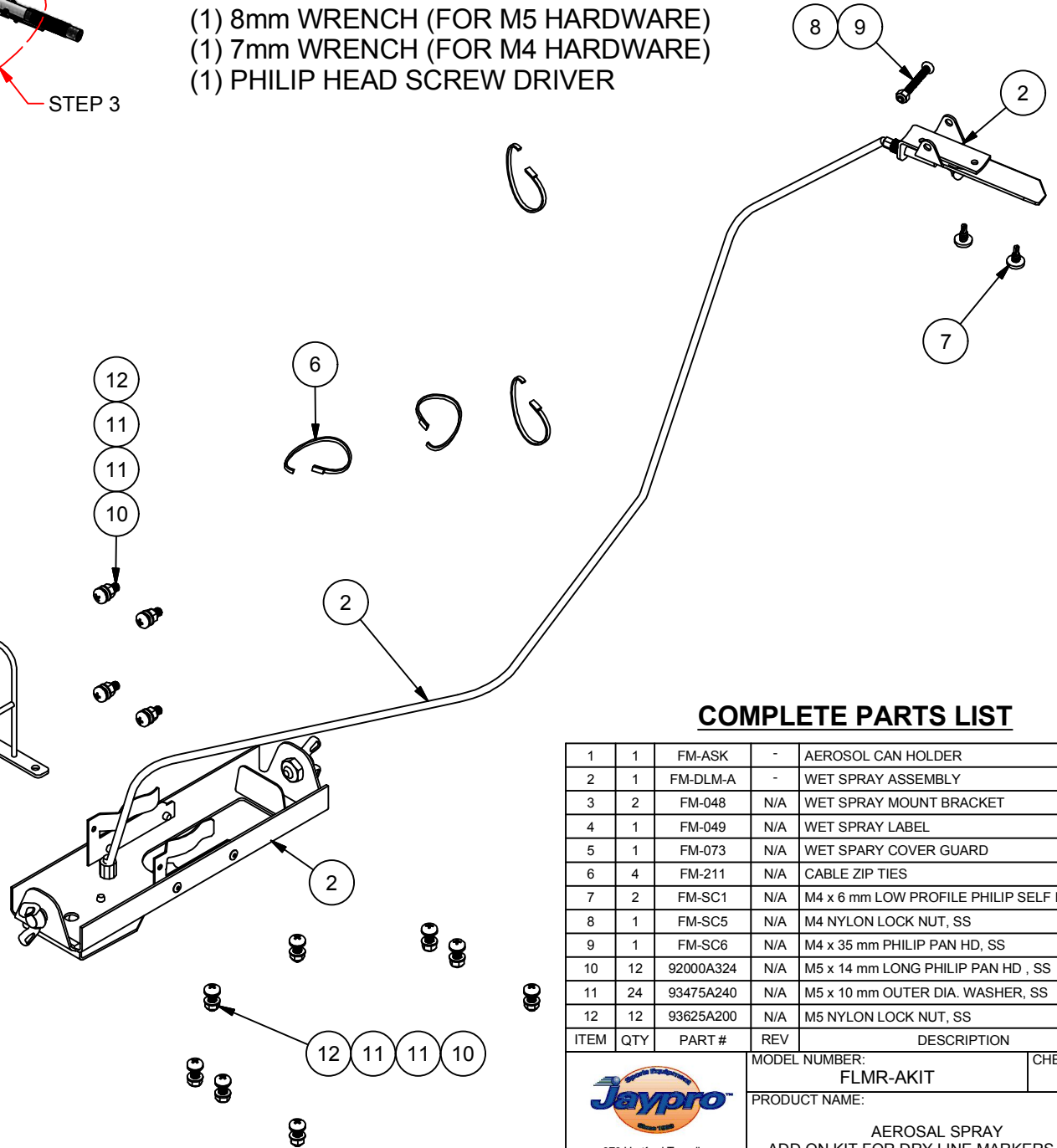

**TOOLS REQUIRED:**  
 (1) 8mm WRENCH (FOR M5 HARDWARE)  
 (1) 7mm WRENCH (FOR M4 HARDWARE)  
 (1) PHILIP HEAD SCREW DRIVER

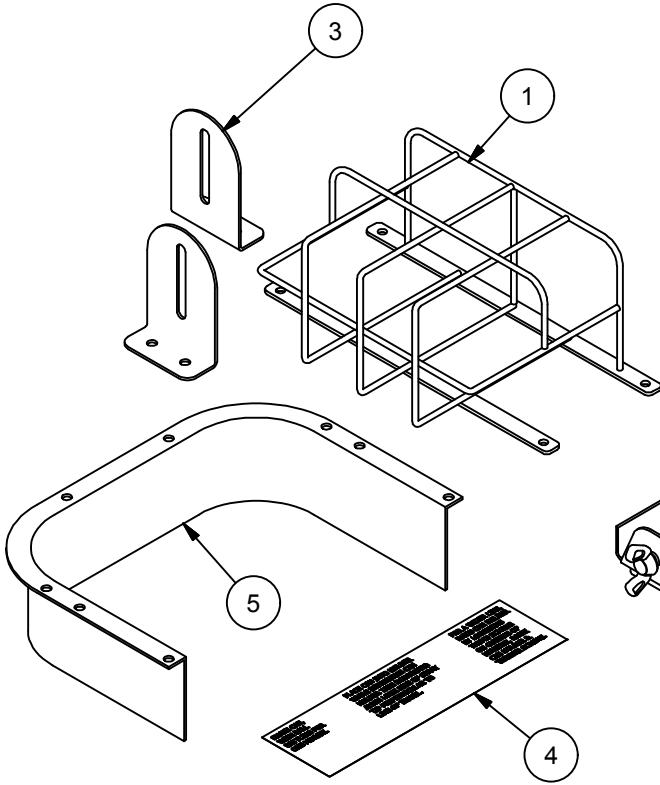

**COMPLETE PARTS LIST**

ITEM	QTY	PART #	REV	DESCRIPTION
1	1	FM-ASK	-	AEROSOL CAN HOLDER
2	1	FM-DLM-A	-	WET SPRAY ASSEMBLY
3	2	FM-048	N/A	WET SPRAY MOUNT BRACKET
4	1	FM-049	N/A	WET SPRAY LABEL
5	1	FM-073	N/A	WET SPARY COVER GUARD
6	4	FM-211	N/A	CABLE ZIP TIES
7	2	FM-SC1	N/A	M4 x 6 mm LOW PROFILE PHILIP SELF DRILL, SS
8	1	FM-SC5	N/A	M4 NYLON LOCK NUT, SS
9	1	FM-SC6	N/A	M4 x 35 mm PHILIP PAN HD, SS
10	12	92000A324	N/A	M5 x 14 mm LONG PHILIP PAN HD, SS
11	24	93475A240	N/A	M5 x 10 mm OUTER DIA. WASHER, SS
12	12	93625A200	N/A	M5 NYLON LOCK NUT, SS

 976 Hartford Turnpike Waterford, CT 06385 USA (800)243-0533 Fax: (800)988-3363 www.jaypro.com		MODEL NUMBER: FLMR-AKIT		CHECKED BY: WVB
		PRODUCT NAME: AEROSOL SPRAY ADD ON KIT FOR DRY LINE MARKERS 50/100		
DATE: 8/20/2012	REV: -	DRAWN BY: Moune T.	SHEET: 1 OF 5	

NOTE: WHEELS AND HANDLE BARS NOT SHOWN FOR CLARITY.

TOOLS REQUIRED:

- (1) 8mm WRENCH (FOR M5 HARDWARE)
- (1) PHILIP HEAD SCREW DRIVER

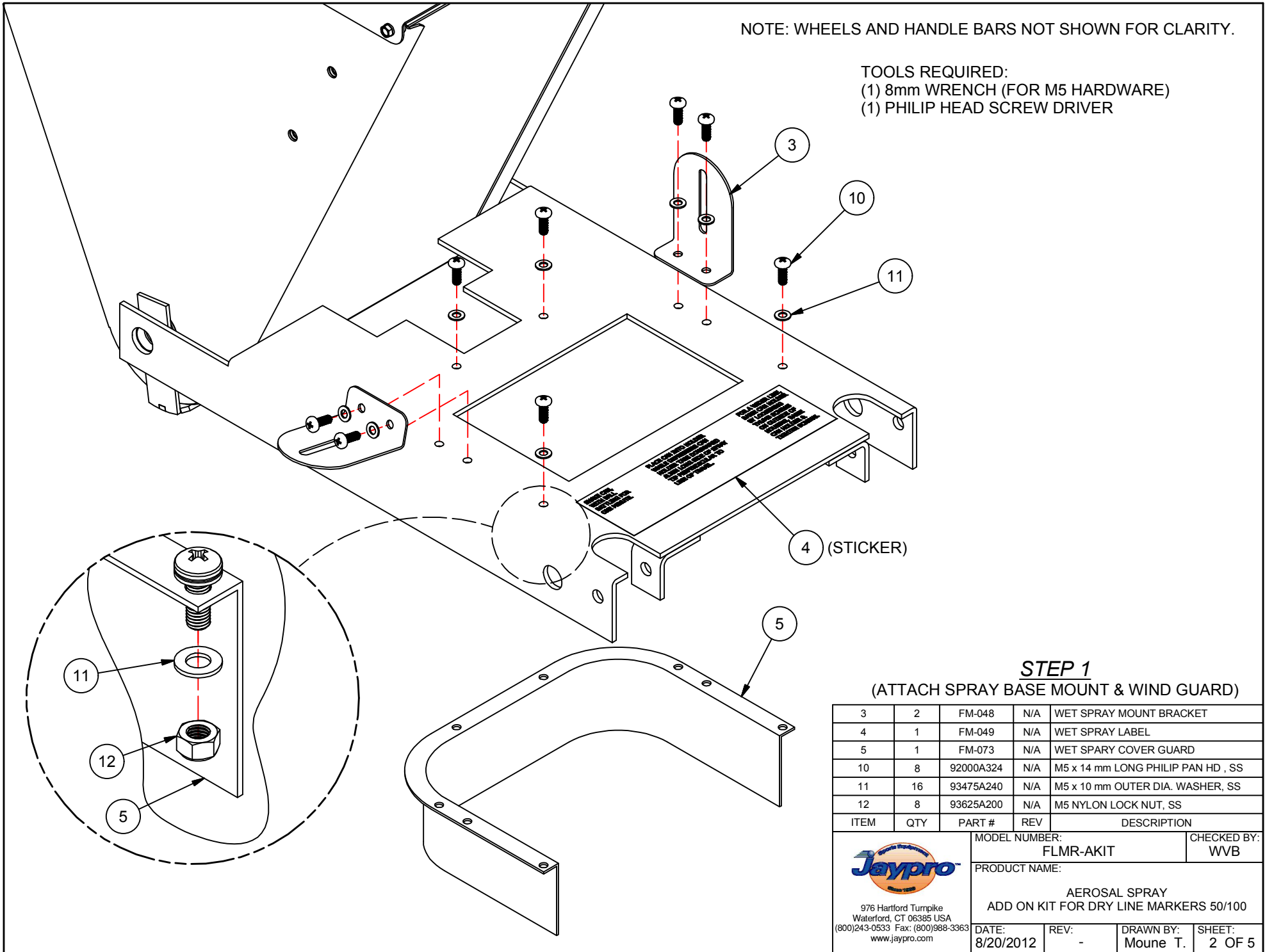

**STEP 1**  
(ATTACH SPRAY BASE MOUNT & WIND GUARD)

3	2	FM-048	N/A	WET SPRAY MOUNT BRACKET
4	1	FM-049	N/A	WET SPRAY LABEL
5	1	FM-073	N/A	WET SPARY COVER GUARD
10	8	92000A324	N/A	M5 x 14 mm LONG PHILIP PAN HD , SS
11	16	93475A240	N/A	M5 x 10 mm OUTER DIA. WASHER, SS
12	8	93625A200	N/A	M5 NYLON LOCK NUT, SS
ITEM	QTY	PART #	REV	DESCRIPTION



976 Hartford Turnpike  
Waterford, CT 06385 USA  
(800)243-0533 Fax: (800)988-3363  
www.jaypro.com

MODEL NUMBER:  
FLMR-AKIT

CHECKED BY:  
WVB

PRODUCT NAME:  
AEROSOL SPRAY  
ADD ON KIT FOR DRY LINE MARKERS 50/100

DATE: 8/20/2012	REV: -	DRAWN BY: Moune T.	SHEET: 2 OF 5
--------------------	-----------	-----------------------	------------------

NOTE: WHEELS AND HANDLE BARS NOT SHOWN FOR CLARITY

TOOLS REQUIRED:  
(1) 7mm WRENCH (FOR M4 HARDWARE)

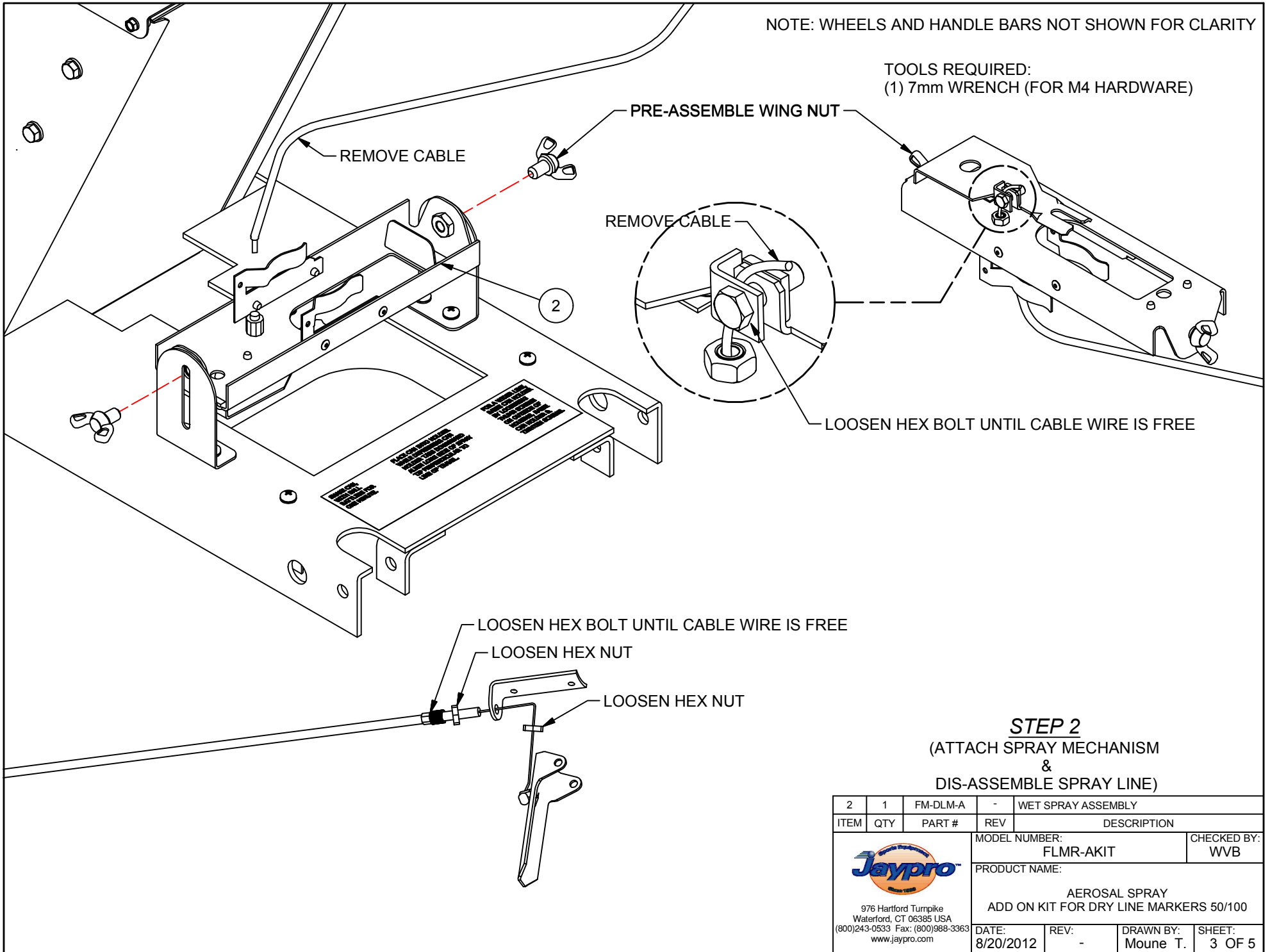

**STEP 2**  
(ATTACH SPRAY MECHANISM  
&  
DIS-ASSEMBLE SPRAY LINE)

2	1	FM-DLM-A	-	WET SPRAY ASSEMBLY	
ITEM	QTY	PART #	REV	DESCRIPTION	
		MODEL NUMBER:		CHECKED BY:	
		FLMR-AKIT		WVB	
		PRODUCT NAME:			
		AEROSOL SPRAY ADD ON KIT FOR DRY LINE MARKERS 50/100			
		DATE:	REV:	DRAWN BY:	SHEET:
		8/20/2012	-	Moune T.	3 OF 5



976 Hartford Turnpike  
Waterford, CT 06385 USA  
(800)243-0533 Fax: (800)988-3363  
www.jaypro.com

NOTE: WHEELS AND HANDLE BARS NOT SHOWN FOR CLARITY

TOOLS REQUIRED:  
 (1) 7mm WRENCH (FOR M4 HARDWARE)  
 (1) PHILIP HEAD SCREW DRIVER

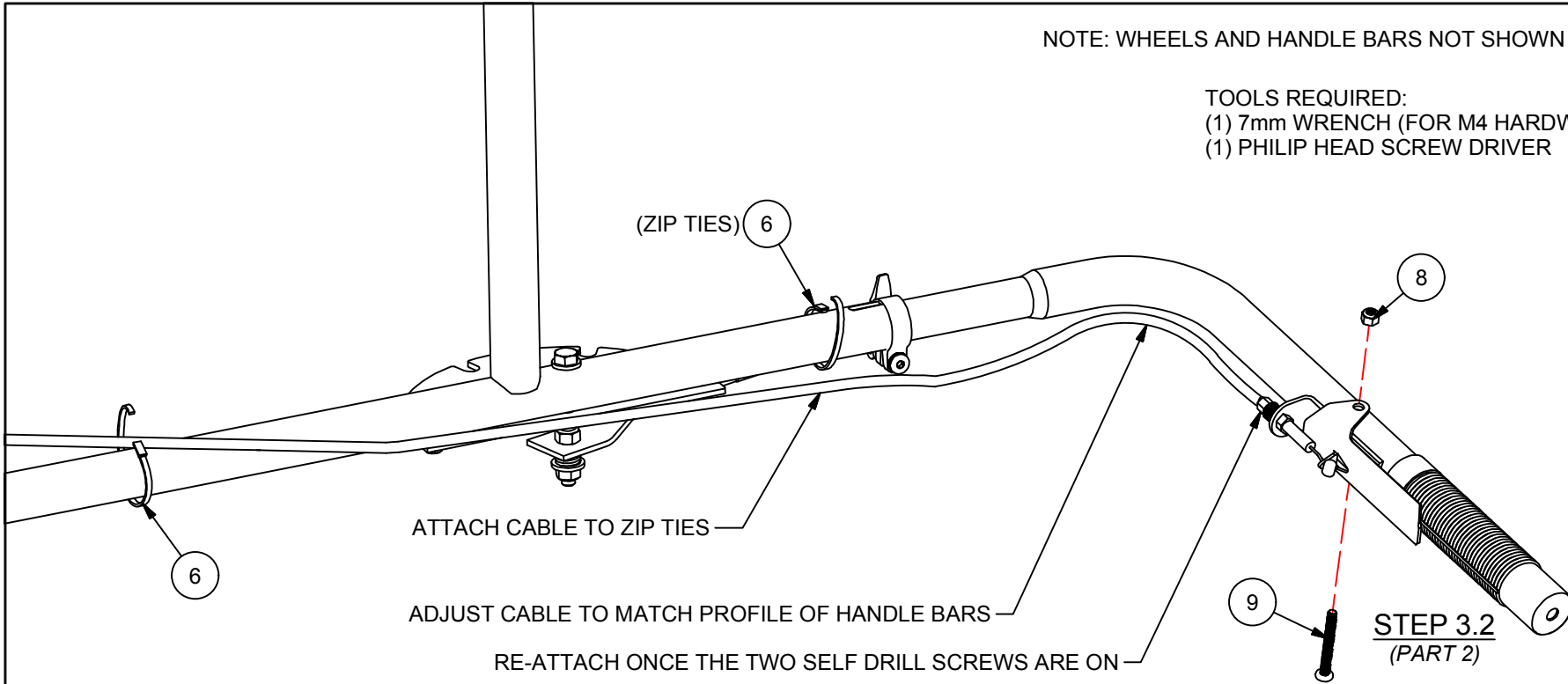

**STEP 3.2**  
(PART 2)

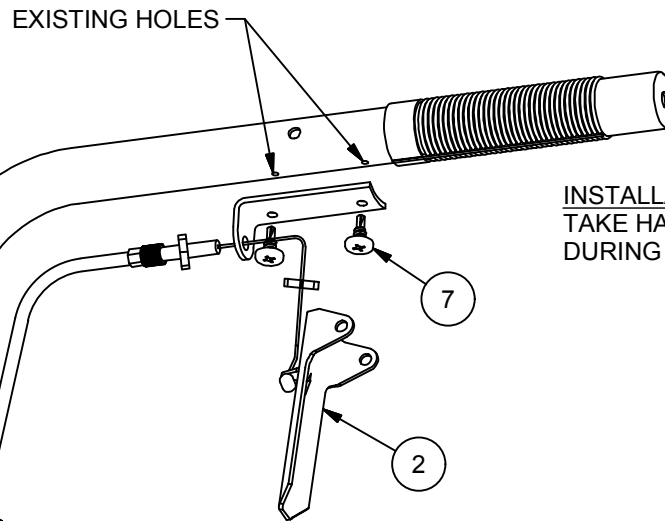

**STEP 3.1**  
(PART 1)

INSTALLATION NOTE:  
 TAKE HANDLE BAR OFF  
 DURING ASSEMBLY OF SPRAY LINE

**STEP 3**  
(ATTACH SPRAY LINE TO HANDLE BARS)

ITEM	QTY	PART #	REV	DESCRIPTION
2	1	FM-DLM-A	-	WET SPRAY ASSEMBLY
6	2	FM-211	N/A	CABLE ZIP TIES
7	2	FM-SC1	N/A	M4 x 6 mm LOW PROFILE PHILIP SELF DRILL, SS
8	1	FM-SC5	N/A	M4 NYLON LOCK NUT, SS
9	1	FM-SC6	N/A	M4 x 35 mm PHILIP PAN HD, SS

 976 Hartford Turnpike Waterford, CT 06385 USA (800)243-0533 Fax: (800)988-3363 www.jaypro.com	MODEL NUMBER: FLMR-AKIT		CHECKED BY: WVB	
	PRODUCT NAME: AEROSOL SPRAY ADD ON KIT FOR DRY LINE MARKERS 50/100			
	DATE: 8/20/2012	REV: -	DRAWN BY: Moune T.	SHEET: 4 OF 5

NOTE: WHEELS AND PREVIOUS STEPS NOT SHOWN FOR CLARITY.

TOOLS REQUIRED:  
 (1) 8mm WRENCH (FOR M5 HARDWARE)  
 (1) PHILIP HEAD SCREW DRIVER

RE-INSERT CABLE

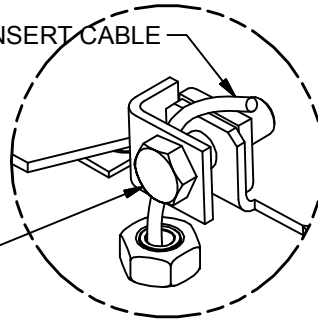

ADJUST TENSION BY LENGTHEN EXPOSE CABLE  
 ONCE SATISFIED, TIGHTEN HEX BOLT SECURELY.

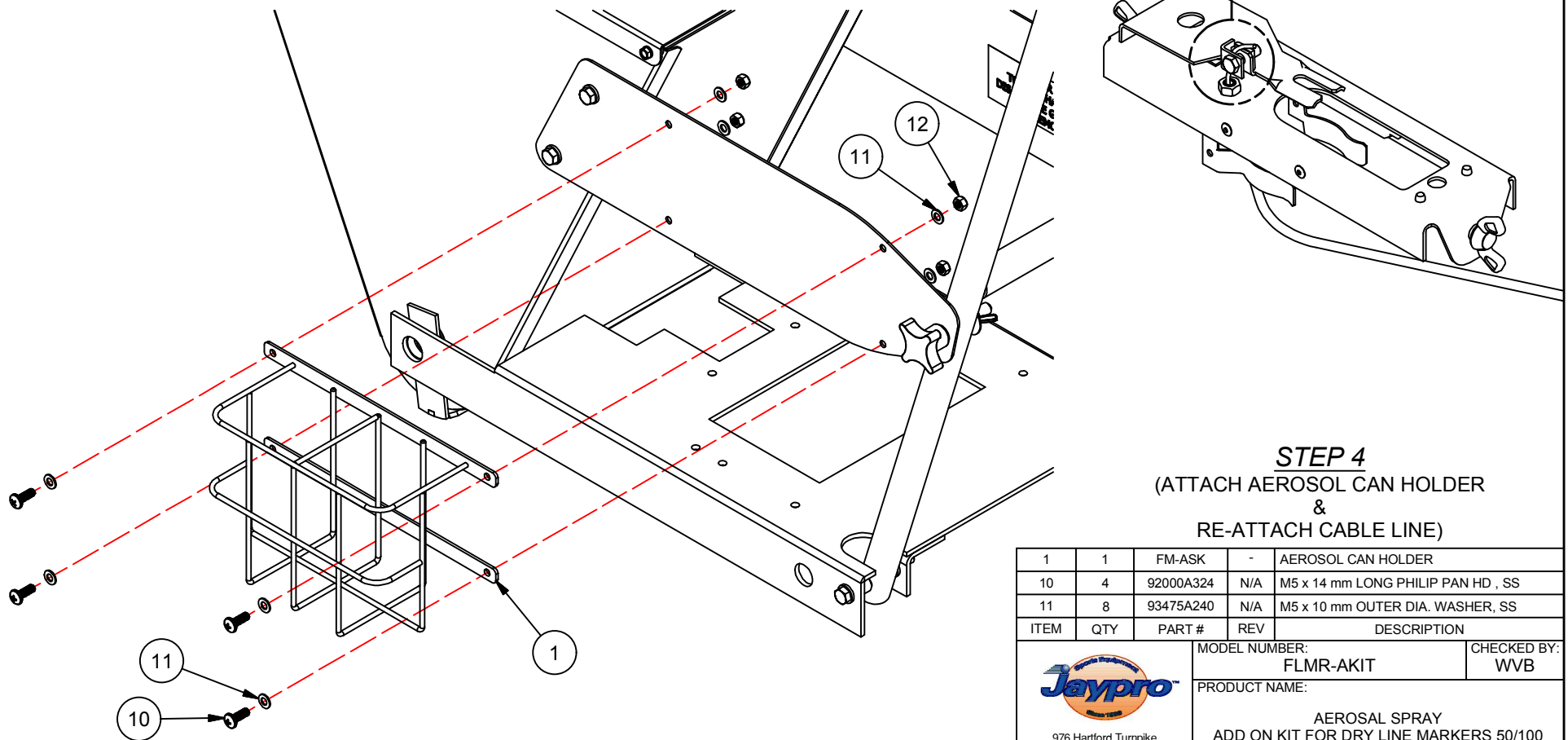

**STEP 4**  
 (ATTACH AEROSOL CAN HOLDER  
 &  
 RE-ATTACH CABLE LINE)

ITEM	QTY	PART #	REV	DESCRIPTION
1	1	FM-ASK	-	AEROSOL CAN HOLDER
10	4	92000A324	N/A	M5 x 14 mm LONG PHILIP PAN HD , SS
11	8	93475A240	N/A	M5 x 10 mm OUTER DIA. WASHER, SS

 976 Hartford Turnpike Waterford, CT 06385 USA (800)243-0533 Fax: (800)988-3363 www.jaypro.com		MODEL NUMBER: FLMR-AKIT		CHECKED BY: WVB
		PRODUCT NAME: AEROSOL SPRAY ADD ON KIT FOR DRY LINE MARKERS 50/100		
DATE: 8/20/2012	REV: -	DRAWN BY: Moune T.	SHEET: 5 OF 5	