

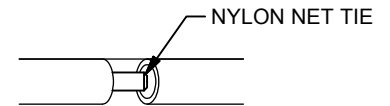

# GBA-180 COMPETITOR 180° BREAKAWAY GOAL

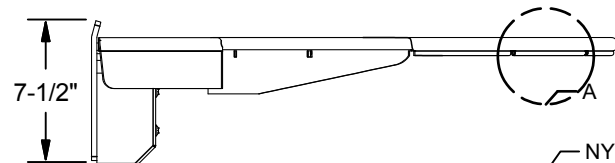

**DETAIL A**  
HIDEAWAY NET ATTACHMENT SYSTEM  
(12 PLACES)

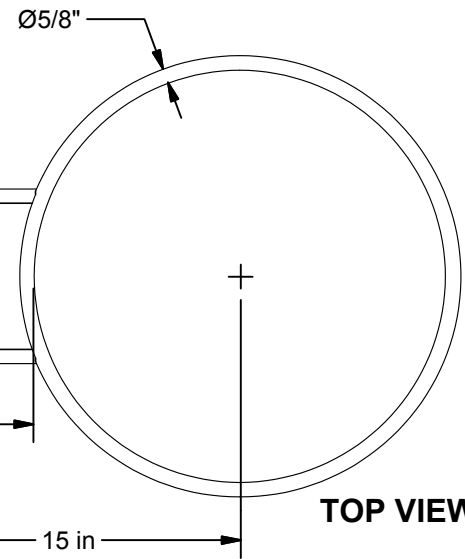
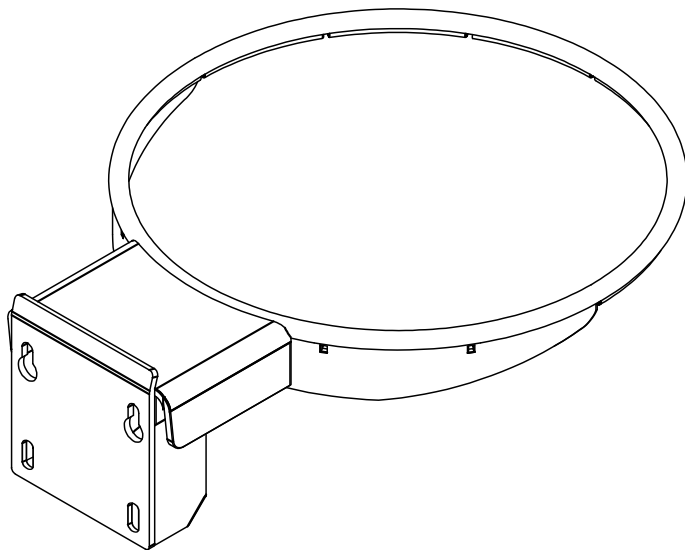
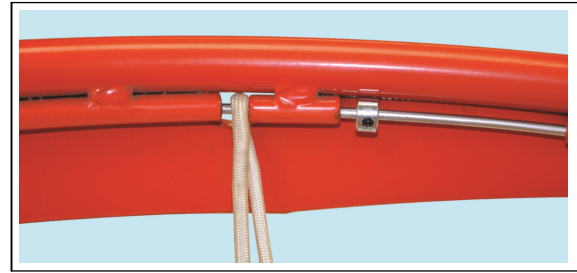
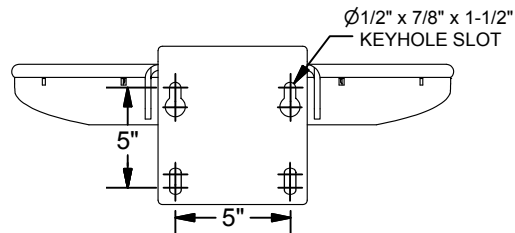

PROJECT NAME \_\_\_\_\_

PROJECT NUMBER \_\_\_\_\_

ARCHITECT \_\_\_\_\_

CONTRACTOR \_\_\_\_\_

NOTES \_\_\_\_\_



**GBA-180**  
 COMPETITOR 180° BREAKAWAY GOAL  
 FOR 48" RECTANGULAR BACKBOARD  
 © COPYRIGHT 2014 JAYPRO SPORTS, LLC. ALL RIGHTS RESERVED  
 THIS PRINT IS THE PROPERTY OF JAYPRO SPORTS, LLC. AND MAY  
 NOT BE REPRODUCED WITHOUT WRITTEN PERMISSION

www.jaypro.com  
 (800) 243-0533  
 976 Hartford Turnpike  
 Waterford, CT 06385 USA  
 Sheet 1 of 2



## SPECIFICATION SHEET

Official Basketball Goal is manufactured to meet all NCAA, FIBA, and NFSA regulations. 18" inside diameter ring is manufactured out of 5/8" diameter steel rod. Bracing of the ring is by 3/16" die cut steel brace welded to the underside of the ring. Hideaway net attachment system located on the underside of the ring to secure the anti-whip net (included). Hideaway system consists of a series of series of tubes welded to the underside of the 5/8" ring with an 1/8" nylon cord revolved through the tubes and net. Hideaway net system provides maximum player safety and a sleek net attachment.

The ring shall be attached to a positive lock pressure release mechanism that allows the ring to release in any direction when someone "slam dunks" the ball or hangs on the ring. The mechanism also absorbs the energy associated with those actions. The goal is pre-set to 180 lbs - 230 lbs. The mechanism is completely field adjustable and can be easily set to provide rebound characteristics that are identical characteristics of non-movable rings per NCAA recommendations.

The attachment flange shall position the inside of the ring 6" from the face of the backboard. The complete goal shall be finished in a durable orange finish. Complete with mounting hardware, the GBA-180 incorporates a mounting plate that allows mounting to a 48" rectangular backboard.

### **WARRANTY**

The GBA-180 Competitor 180° Breakaway Goal shall have a limited warranty for a period of (5) five years.