

REV	DESCRIPTION	BY	DATE
A	PVBN-6 WAS PVBN-1	DRL	11/18/2010

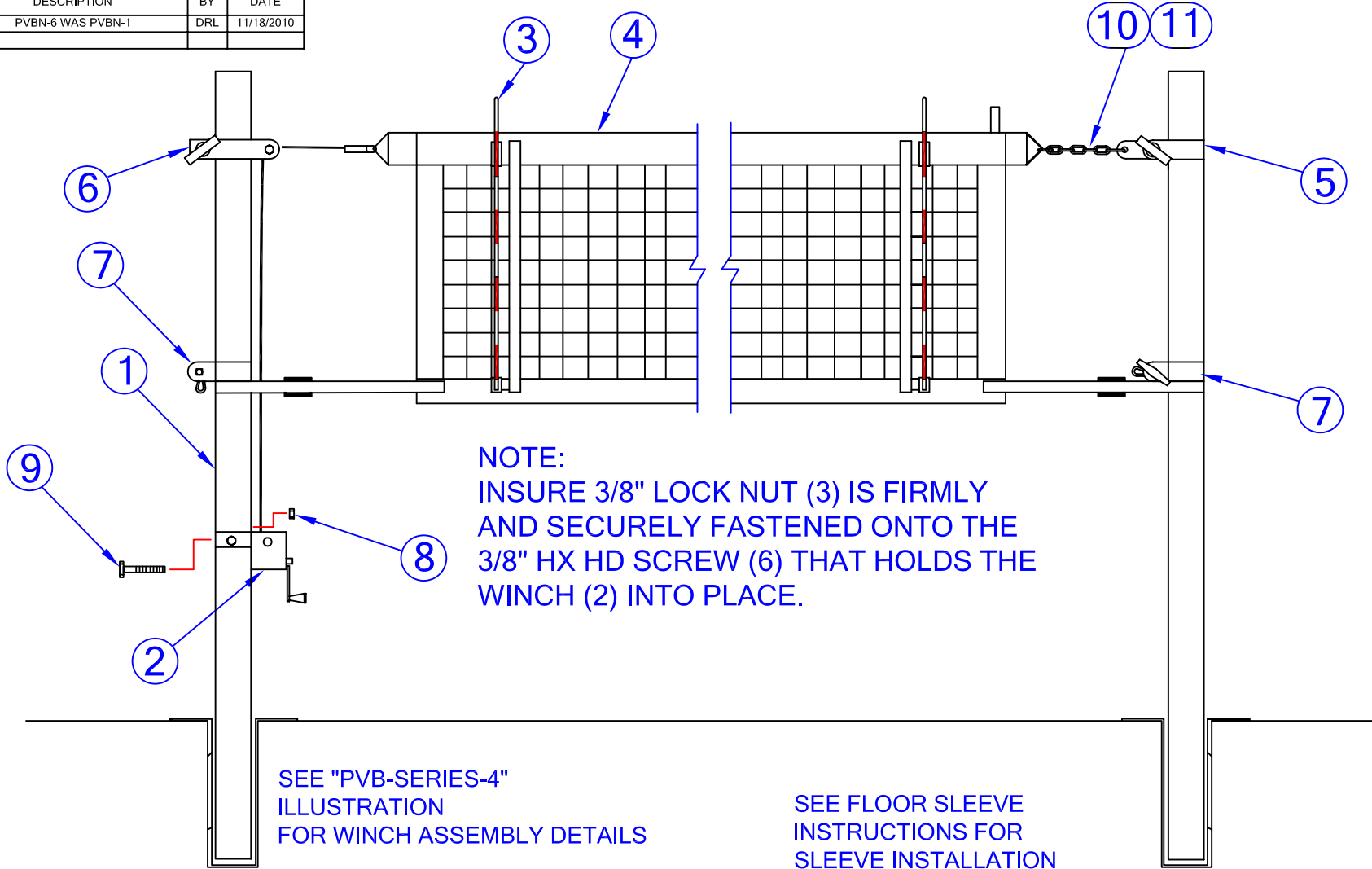

SEE "PVB-SERIES-4"
ILLUSTRATION
FOR WINCH ASSEMBLY DETAILS

SEE FLOOR SLEEVE
INSTRUCTIONS FOR
SLEEVE INSTALLATION

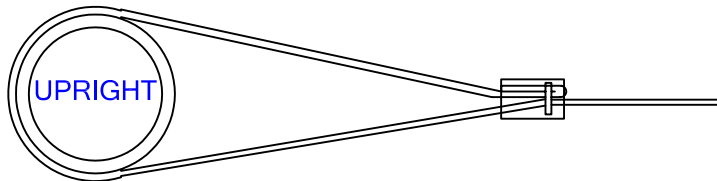

ATTACH THE BOTTOM NET STRAP TO EACH UPRIGHT AS SHOWN. WRAP VELCRO STRAPS AROUND BUCKLES FOR ADDITIONAL PLAYER SAFETY.



MODEL NAME:	PVB-1350 INST	CHECKED BY:	WVB
DESCRIPTION:	PVB-1350 VOLLEYBALL SYSTEM		
DATE:	11/24/10	REV:	-
DRAWN BY:	DRL		

JAYPRO SPORTS
POWER VOLLEYBALL, PVB-1350
LIST OF MATERIALS

<u>PIECE NO.</u>	<u>PART NO.</u>	<u>DESCRIPTION</u>	<u>QTY.</u>
1	VB-1350U	UPRIGHT	2
2	VBWINCH	WINCH	1
3	VBA-4	VOLLEYBALL ANTENNA	1
4	PVBN-6	VOLLEYBALL NET	1
5	PVB-13-7	ANCHOR END CLAMP COLLAR	1
6	PVB-13-8	TOP ROLLER CLAMP COLLAR	1
7	PVB-13-9	BOTTOM SLIDING COLLAR	2
8	HN265	3/8"-16 NYLON LOCK NUT	1
9	HS294	3/8"-16 x 4 1/2" HX HD CAP SCREW	1
10	HM5019	CARABINER 3/8 x 4	1
11	CN0001-24	CHAIN 24 INCHES	1

ASSEMBLY INSTRUCTIONS

- 1) Assemble winch assembly to upright with hole as shown.
- 2) Place uprights in sleeves (see instructions included in with the sleeves for their installation).
- 3) Place bottom sliding collars over the poles approximately 3 feet beyond where top net height will be. Tighten wing bolts just enough to hold in place. You will need to fine tune their location later.
- 4) Place top roller clamp collar on pole and position top of clamp approximately 3/4" higher than the desired net height. For example if you are setting net to women's volleyball height, (7'-4 1/8") set the top of the collar to 7'-4 7/8". Align clamp collar with winch assembly and tighten securely.
- 5) Place top anchor end clamp collar on the pole and position approximately 1 1/4" higher than desired net height (see above). Tighten securely.
- 6) Slip the net dowels into the side pockets on each end of the net. Position the net between the 2 uprights.
- 7) Thread the webbing strap from the winch over the roller clamp and connect the end of the cable to the snap buckle. Connect the other end of the net to a Carabiner and the length of chain provided and attach that end of the chain to the top anchor end clamp (step 5) with the other Carabiner.
- 8) Adjust the length of the chain as necessary to center net on court.
- 9) The net will stretch ~6-8 inches when tension is applied so you must factor this in before applying tension and when centering the net.
- 10) Slowly tension the top webbing strap by cranking the winch with the winch handle. Adjust chain as necessary to keep the net centered.
- 11) Verify net heights and net centering. The uprights will deflect inward and downward due to net tension; you may need to adjust heights and /or re-center the net. **Warning: Release tension from the net before loosening any hardware from the uprights.**
- 12) Attach the bottom net straps by wrapping the long ends of the net side straps around the uprights below the bottom sliding collars and fasten them through the buckles located on the opposite side. Wrap the Velcro straps around buckles for additional player safety. For best results, adjust the side straps so that the volleyball net will be centered within the playing area.
- 13) Raise the center of the net to the full official net height by cranking the handle. Adjust all net side straps to further tension the net.
- 14) When releasing the tension on the unit unfasten the bottom straps first, then release the tension on the top.
- 15) To remove the unit for storage, disconnect the net from the 2 uprights and carefully lift each upright from the floor sleeve.
- 16) For player safety cut any excess chain before putting system into service.

INSTALLATION AND USE CONSIDERATIONS

- 1) The unit is designed for high level competition play. Consequently, when installed and operational, the unit is subject to considerable stress loads. It is essential to inspect all parts before each use.
- 2) Do not use this equipment without the protective upright padding properly fastened in place.

3 1/2" UPRIGHT

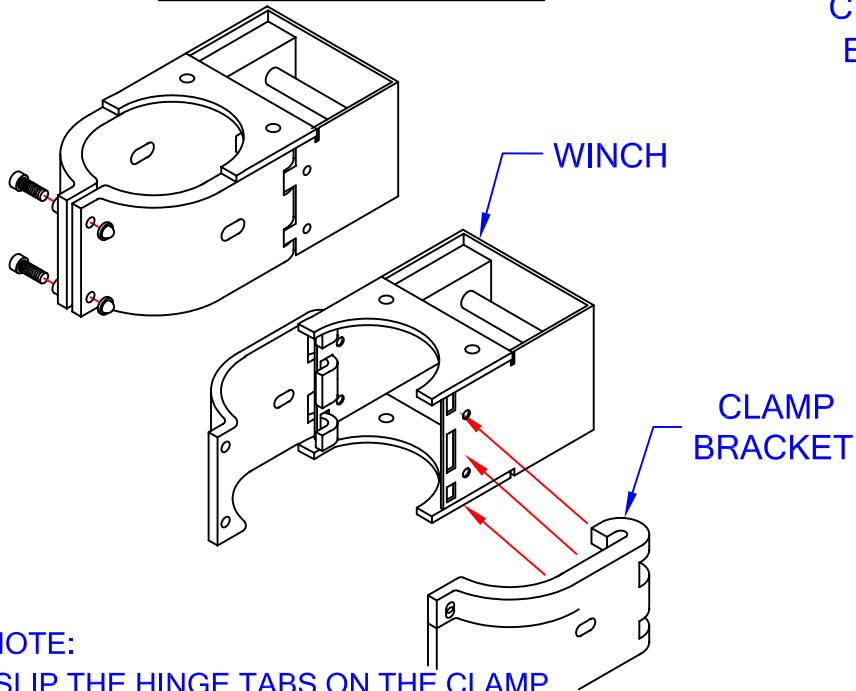

- NOTE:**
- SLIP THE HINGE TABS ON THE CLAMP BRACKET INTO THE HINGE SLOTS ON THE WINCH HOUSING.
 - OPEN THE CLAMPS AND PLACE THE WINCH ASSEMBLY ONTO THE VOLLEYBALL STANCHION. ALIGN SLOT IN CLAMP BRACKET WITH MOUNTING HOLES ON STANCHION.
 - FIRMLY SECURE THE CLAMP BOLTS THEN ADD THE CAP NUTS TO COVER THE ENDS OF EACH CLAMP BOLT. SEE "PVB-SERIES-2" ILLUSTRATION FOR WINCH MOUNTING DETAILS.

3" UPRIGHT

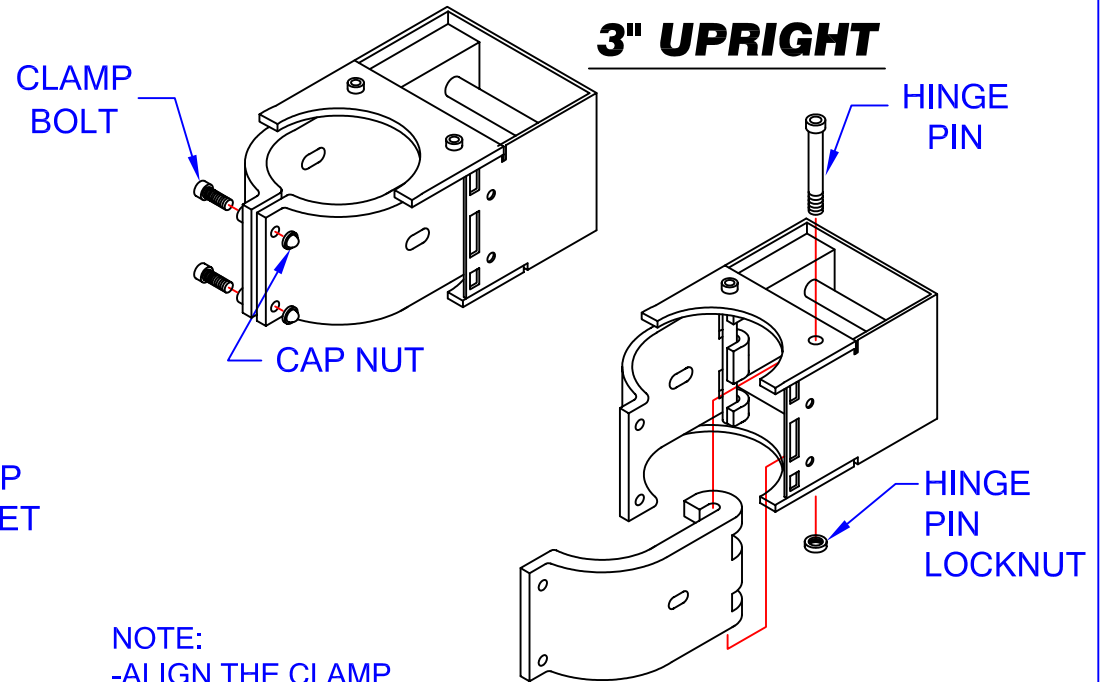

- NOTE:**
- ALIGN THE CLAMP BRACKETS TO THE INSIDE OF THE WINCH HOUSING, SLIP THE HINGE PIN THRU THE HINGE TABS OF THE CLAMP BRACKET, THEN SECURELY FASTEN WITH THE HINGE PIN LOCKNUT.
 - SLIDE THE WINCH ASSEMBLY ONTO THE VOLLEYBALL STANCHION AND ALIGN SLOT IN CLAMP BRACKET WITH MOUNTING HOLES ON STANCHION.
 - FIRMLY SECURE THE CLAMP BOLTS THEN ADD THE CAP NUTS TO COVER THE ENDS OF EACH CLAMP BOLT. SEE "PVB-SERIES-2" ILLUSTRATION FOR WINCH MOUNTING DETAILS.

FOR MODEL: PVB-6000

FOR MODELS: PVB-5000
PVB-7000
PVB-6500
PVB-2500
PVB-2700



976 HARTFORD TURNPIKE
WATERFORD, CT 06385 USA
www.jaypro.com

MODEL NAME: PVB-SERIES		CHECKED BY: WVB
DESCRIPTION: WINCH ASSEMBLY		
DATE: 5-6-03	REV -	DRAWN BY: JAC

ASSEMBLY INSTRUCTIONS:

1. INSTALL POWER VOLLEYBALL SYSTEM AS DESCRIBED IN SEPERATE INSTRUCTIONS
2. PLACE PADS INTO POSITION, AS SHOWN, AND SECURELY FASTEN THE VELCRO CLOSURES AS INDICATED

CAUTION:

DO NOT USE THE POWER VOLLEYBALL SYSTEM WITHOUT THE UPRIGHT PADS

PLEASE NOTE:

- 1) FOR SAFE OPERATION AND CONTINUED HIGH PERFORMANCE FROM THIS EQUIPMENT, INSPECTION AND MAINTENANCE MUST BE PERFORMED BEFORE EACH USE
- 2) USE OF THIS EQUIPMENT OTHER THAN INTENDED, MAY BE HAZARDOUS.
- 3) ALTERATION OR MODIFICATION OF EQUIPMENT MAY BE HAZARDOUS. FOR REPAIR OR REPLACEMENT, PLEASE CALL YOUR DEALER

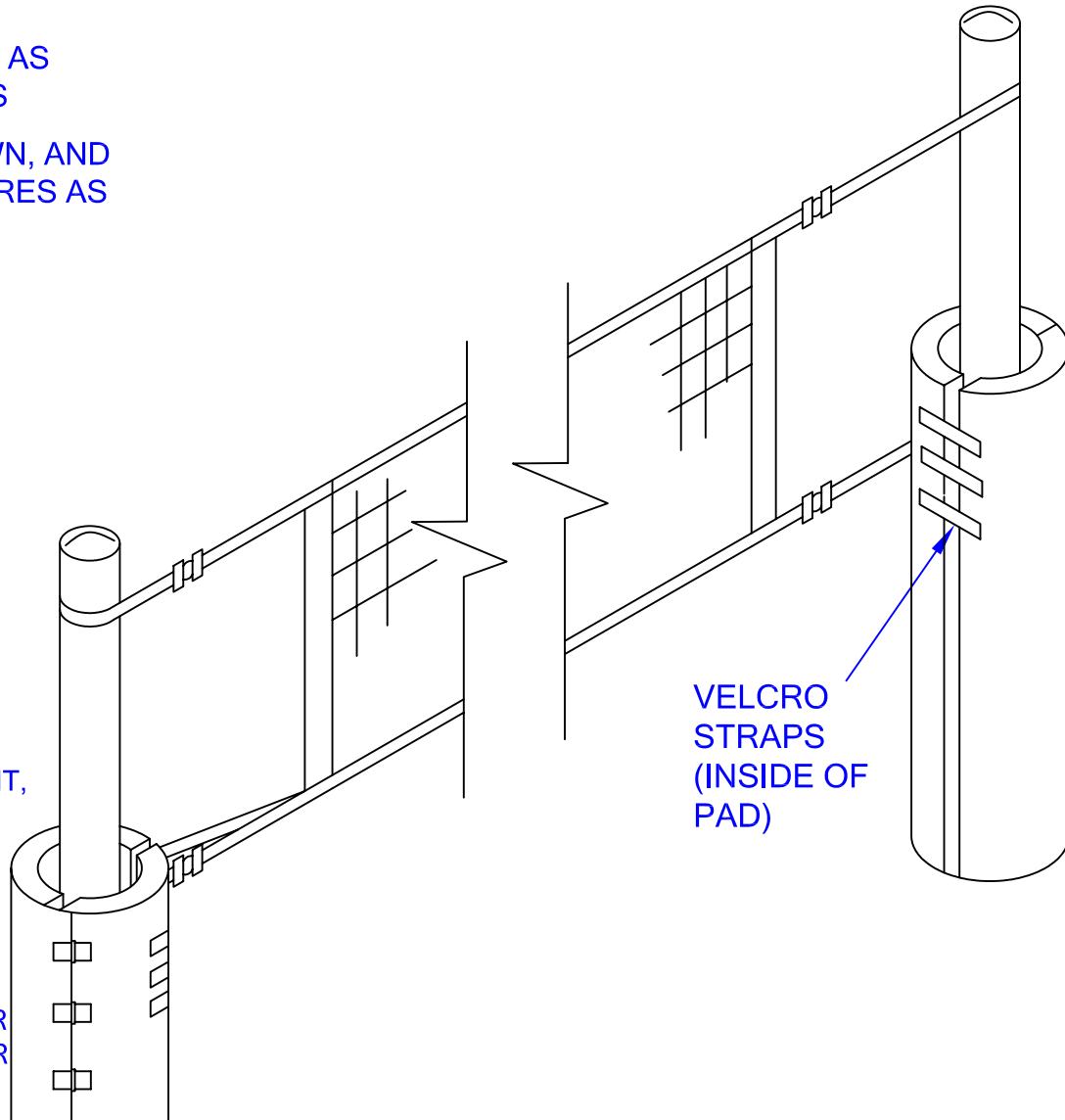

976 HARTFORD TURNPIKE
WATERFORD, CT 06385 USA
www.jaypro.com

MODEL NAME:
PVB-10P

CHECKED BY:
WVB

DESCRIPTION:
**POWER VOLLEYBALL PAD
CUSTOMER INSTALLATION**

DATE:
5-6-03

REV
-

DRAWN BY:
JAC

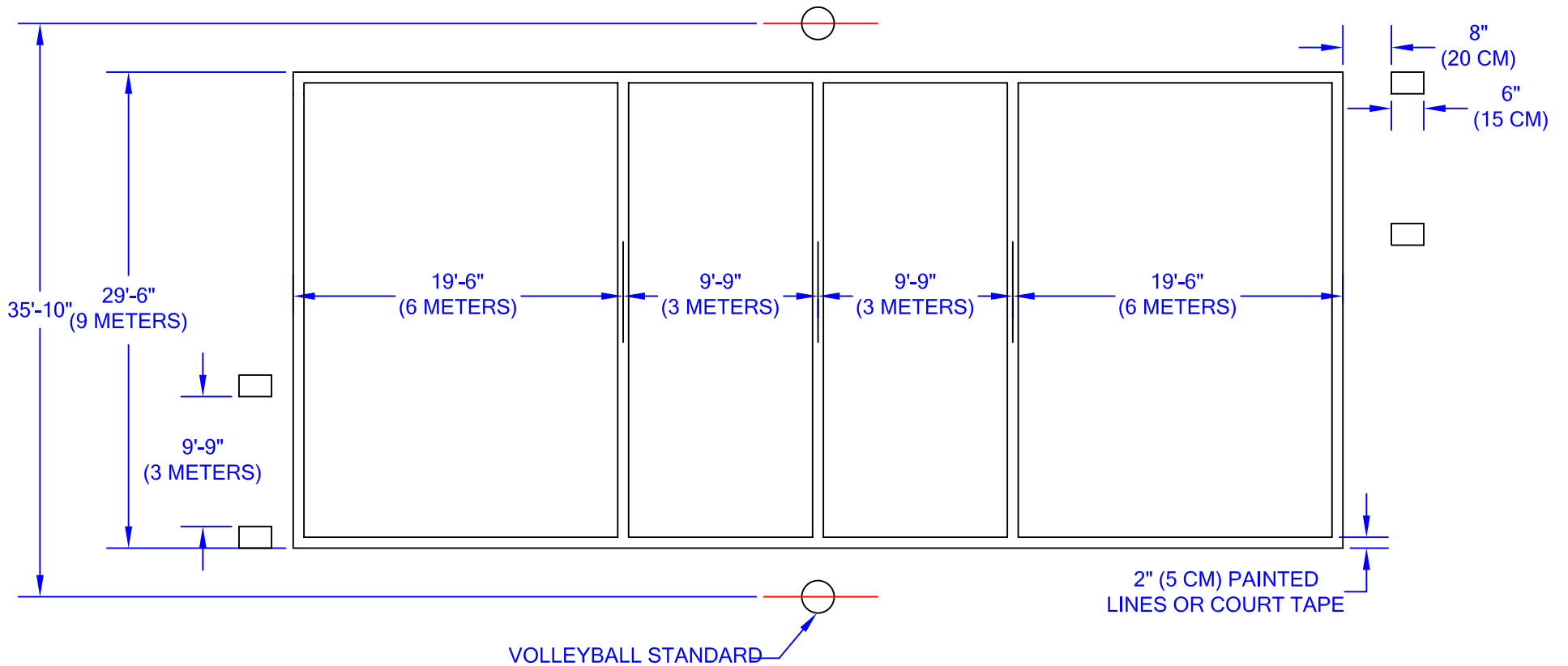

IMPORTANT:

COURT DIMENSIONS SHOWN COMPLY WITH SPECIFICATIONS FOR:

U.S.V.B.A.

F.I.V.B.

N.C.A.A.

COURT SIZE SPECIFICATIONS FOR THE N.F.S.H.S.A. ARE 30'W x 60'L.

CENTER LINE TO BE 4" WIDE.

SPIKE LINE TO BE 10' FROM THE CENTER LINE.

SERVING AREA TO BE 10' LONG.



976 HARTFORD TURNPIKE
 WATERFORD, CT 06385 USA
 www.jaypro.com

MODEL NAME: PVB-1000		CHECKED BY: WVB
DESCRIPTION: POWER VOLLEYBALL COURT LAYOUT		
DATE: 5-6-03	REV -	DRAWN BY: JAC