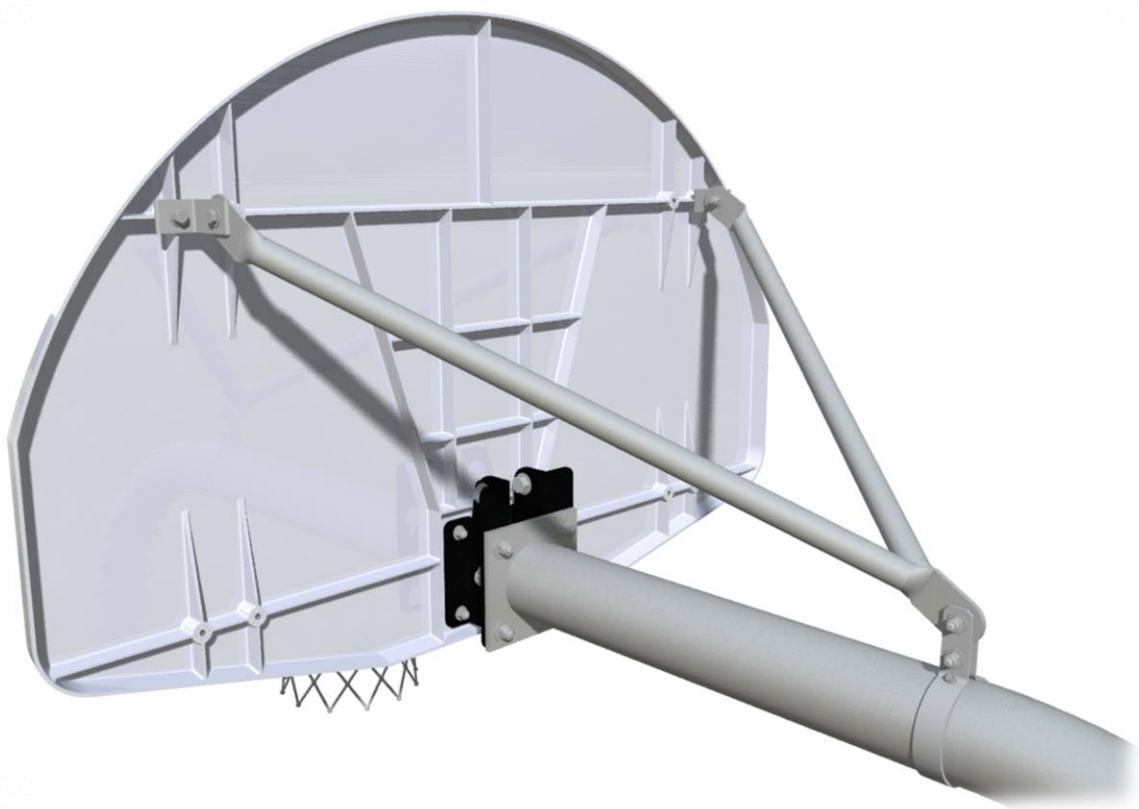




-- HRKIT-FA-DIR --
(WITH THE HOOP REJUVENATOR™)
Installation Instructions



Call Jaypro Sports Equipment at 1-800-243-0533 during regular business hours for technical support.

www.jaypro.com

JAYPRO SPORTS

HRKIT-FA-DIR (RECTANGULAR ACRYLIC BACKBOARD)

IMPORTANT NOTICE:

- 1) INSPECT FOR DAMAGE. REPORT ALL DAMAGES TO TRUCKING COMPANY.
- 2) BEFORE EACH USE CHECK EQUIPMENT FOR PROPER CONNECTING HARDWARE AND STRUCTURAL INTEGRITY. REPLACE DAMAGED OR MISSING HARDWARE IMMEDIATELY.
- 3) USE OF THIS EQUIPMENT OTHER THAN INTENDED, MAY BE HAZARDOUS.
- 4) ALTERATION OR MODIFICATION OF THIS EQUIPMENT MAY BE HAZARDOUS AND RESULT IN INJURY. FOR REPAIR OR REPLACEMENT, CONTACT YOUR DEALER OR JAYPRO SPORTS.




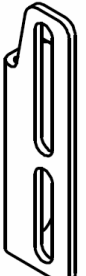
PARTS LIST SHOWN FOR ONE UNIT		
IMAGE	QTY	DESCRIPTION
	1	GOOSENECK BRACKET SIDE A (P/N: SR5507)
	1	GOOSENECK BRACKET SIDE B (P/N: SR5508)
	1	PLUMB ADJUSTMENT BRACKET RIGHT (P/N: SR5505)
	1	PLUMB ADJUSTMENT BRACKET LEFT (P/N: SR5506)
IMAGE	QTY	DESCRIPTION

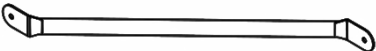
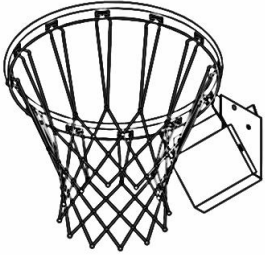
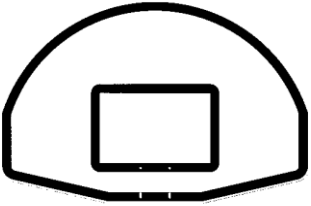
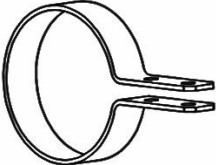




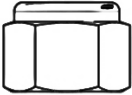
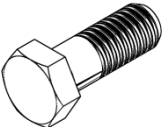
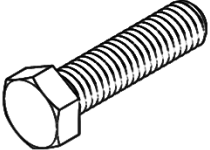
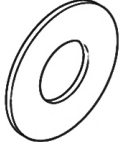
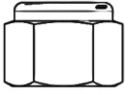
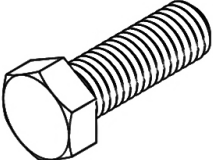
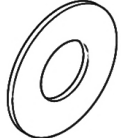

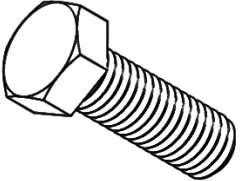
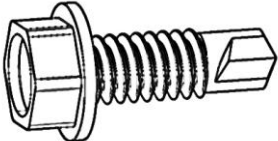
IMAGE	QTY	DESCRIPTION
	2	SUPPORT BRACE (P/N: HRKIT-AC-DRA)
	1	DOUBLE RIM ULTIMATE BREAKAWAY GOAL (P/N: UBG-500F)
	1	FAN ALUMINUM BACKBOARD W/ TARGET (P/N: ALB-24BT)
	1 EA	4-1/2" OD BAND CLAMP (P/N: BRC45) 5-9/16" OD BAND CLAMP (P/N: BRC5916) 6-5/8" OD BAND CLAMP (P/N: BRC658)
	1	CAN OF SPRAY ON ZINC GALVANIZE
	1 EA	MOUNTING TAB (P/N: SR5370)
	2	3/8" LOCK WASHER, SS
	18	3/8" WASHER, SS
	8	3/8"-16 NYLON LOCK NUT, SS
IMAGE	QTY	DESCRIPTION

IMAGE	QTY	DESCRIPTION
	4	3/8\"-16 x 1\" HEX BOLT, SS
	6	3/8\"-16 x 1-1/2\" HEX BOLT, SS
	8	1/2\" WASHER, SS
	4	1/2\"-13 NYLON LOCK NUT, SS
	4	1/2\"-13 x 1-1/2\" HEX BOLT, SS
	8	5/8\" WASHER, SS
	4	5/8\"-11 NYLON LOCKNUT, SS
	4	5/8\"-11 x 1-1/4\" HEX BOLT, SS
	2	1/4\"-14 x 3/4\" SELF TAP HEX SCREW, SS
IMAGE	QTY	DESCRIPTION

TOOLS REQUIRED:

- (1) 9/16" Socket Wrench and Box Wrench
- (1) 3/4" Socket Wrench and Box Wrench
- (1) 15/16" Socket Wrench and Box Wrench
- (1) Level Device
- (1) Scaffolding, Lull or Lift
- (1) 10 or 12 FT Step Ladder
(for final adjustments)

Important Note:

Installation of the Hoop Rejuvenator system requires the lifting and handling of substantial weight, up to 270 lbs. Safe installation requires at least three men and the use of appropriate material handling equipment such as scaffolding, a Lull or lift.

DO NOT ATTEMPT TO ASSEMBLE THE HOOP REJUVENATOR OFF A STEP LADDER.

The Hoop Rejuvenator offers the ability to adjust the height of the board and plumb it independently. Care should be taken at each step to ensure the framework is square and plumb.

Upright Assembly:

1. Uninstall the existing backboard and brace that's on the gooseneck.
2. With the can of spray on galvanize, spray any area that is rusted. Allow galvanize to dry before continuing.
3. Attach the H-Frame gooseneck bracket together as shown *(figure 1)*.

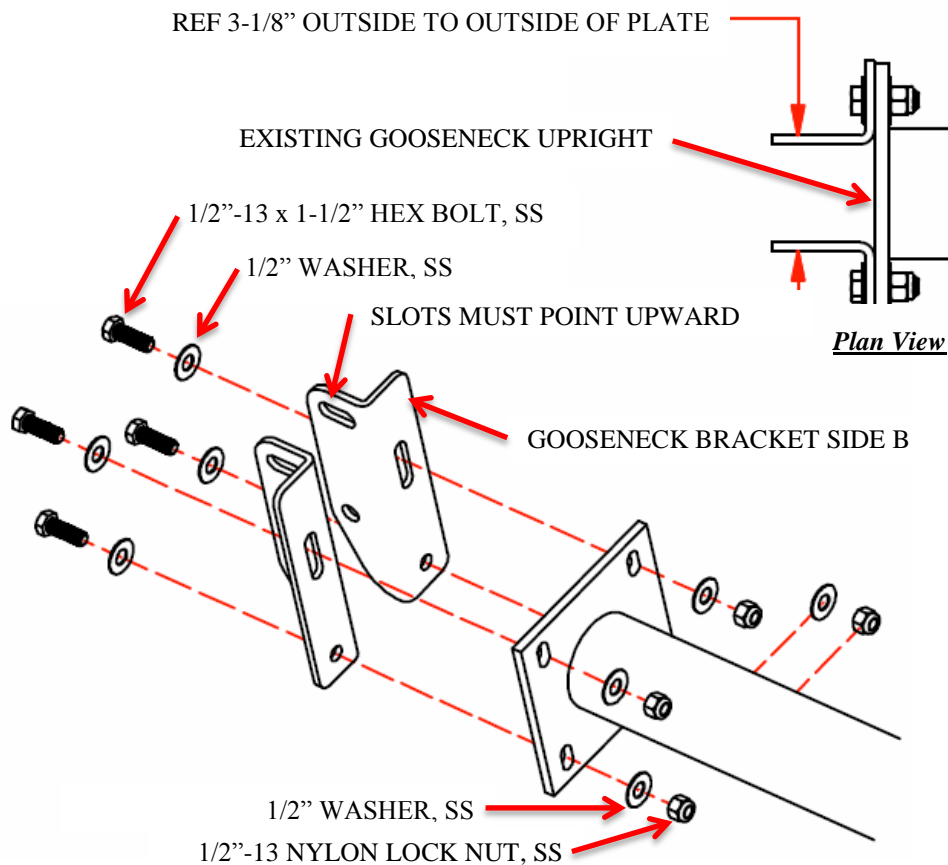


Figure 1

Frame Support Attachment:

1. Loosely assembly brackets together with 5/8" hardware as shown in figure 2.
2. Measure and set 119" to the top slot from the playing surface see figure 3.
3. Three band clamps are provided; use only one that fits the existing gooseneck. Stretch the band clamp on to the existing gooseneck and close it as shown in figure 4.

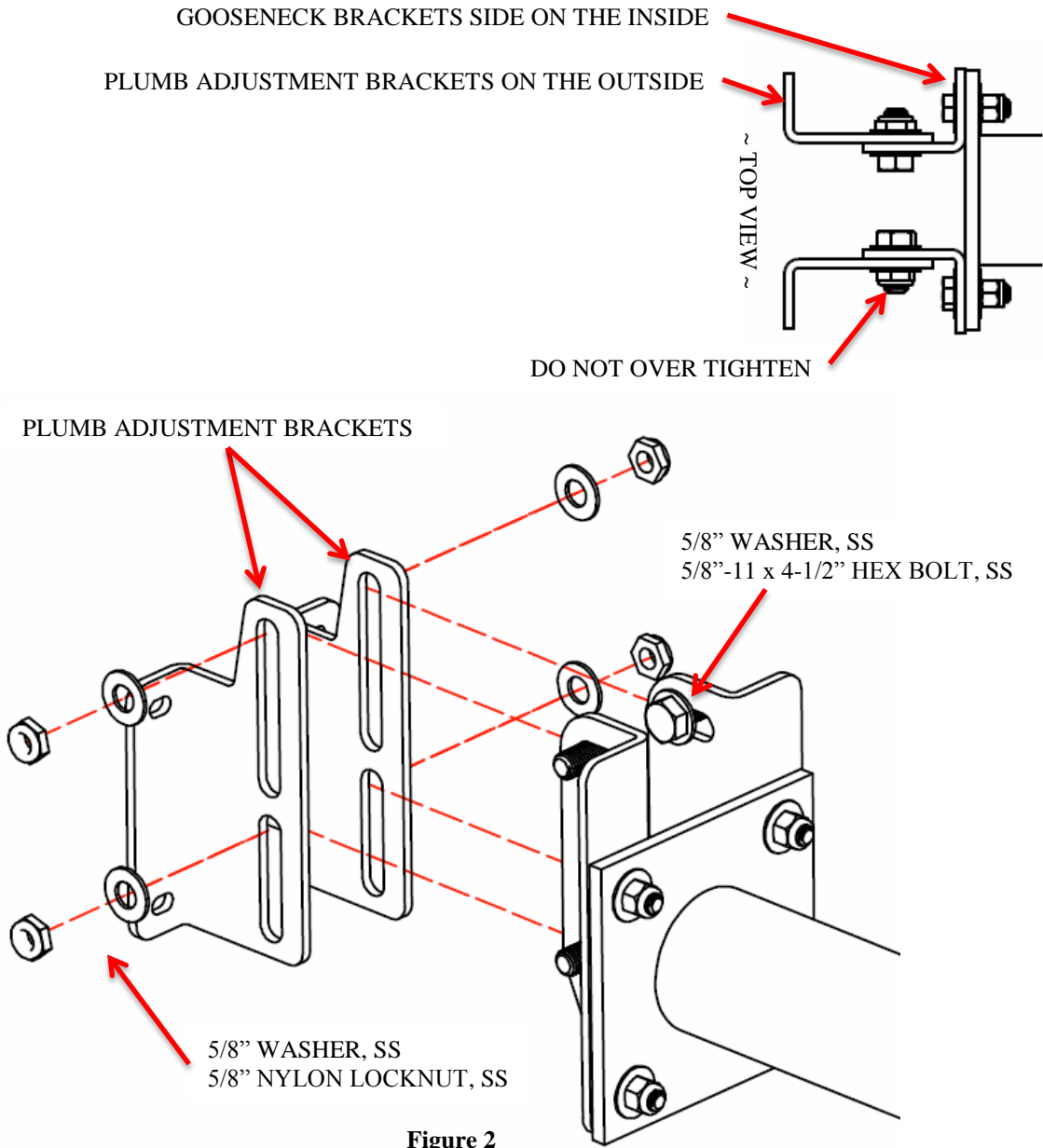
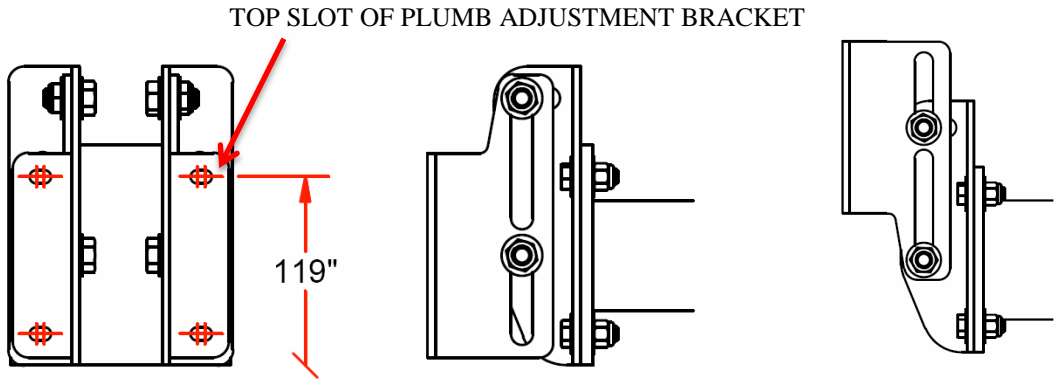


Figure 2



STANDARD HEIGHT ADJUSTMENT:
0" THRU 2-1/2" SHOWN ABOVE

LARGER HEIGHT ADJUSTMENT:
FLIP PLATES TO GAIN
2-1/2" THRU 5" HEIGHT

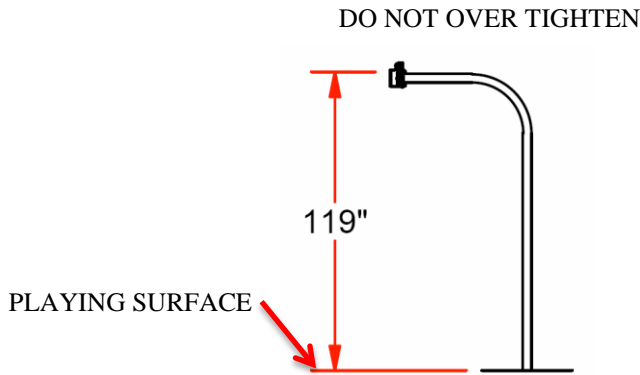
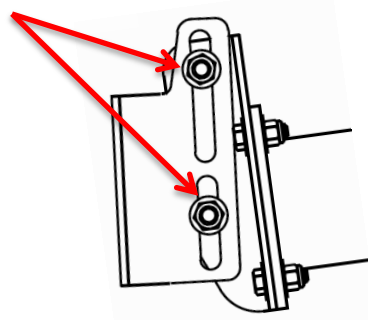


Figure 3



IMPORTANT:
MAINTAIN THE PLUMB TO THE
PLAYING SURFACE!

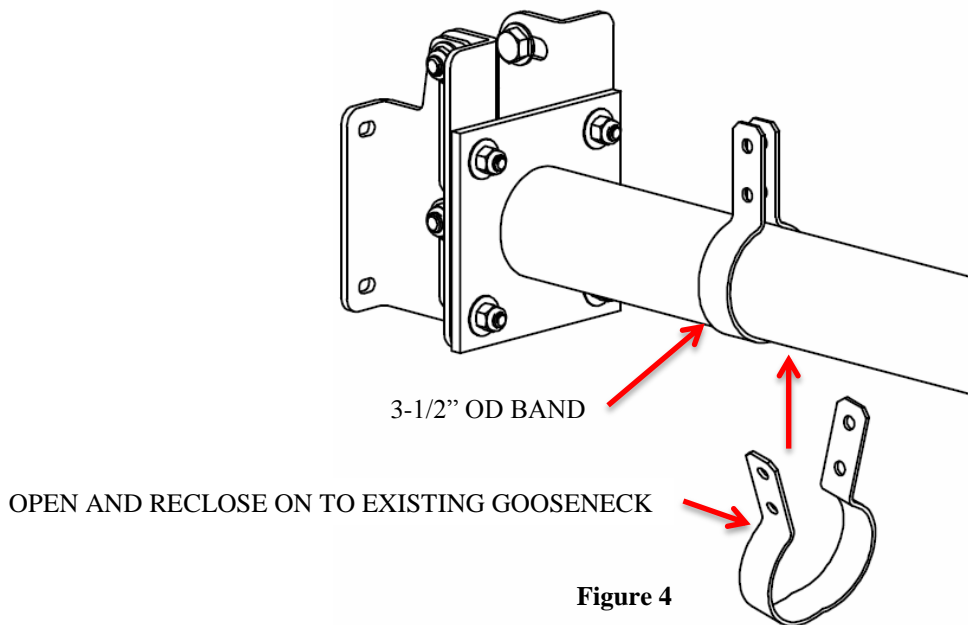
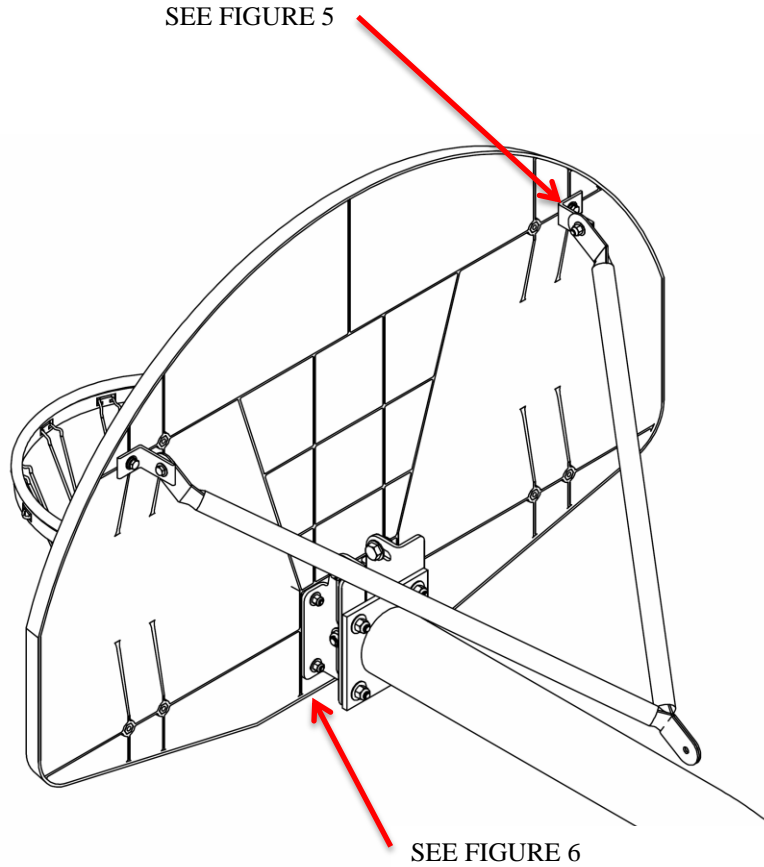


Figure 4

Board Assembly:

1. Attach the appropriate brace mounting bracket to the back of the backboard as shown in figure 5.
2. Lift entire backboard and assembly the goal on to the board and brackets as shown in figure 6.
3. Once backboard and goal is on the gooseneck, plumb the board to the playing surface. Maintain the plumb and lock it in place using the 3-1/2" OD band clamp as shown in figure 7.



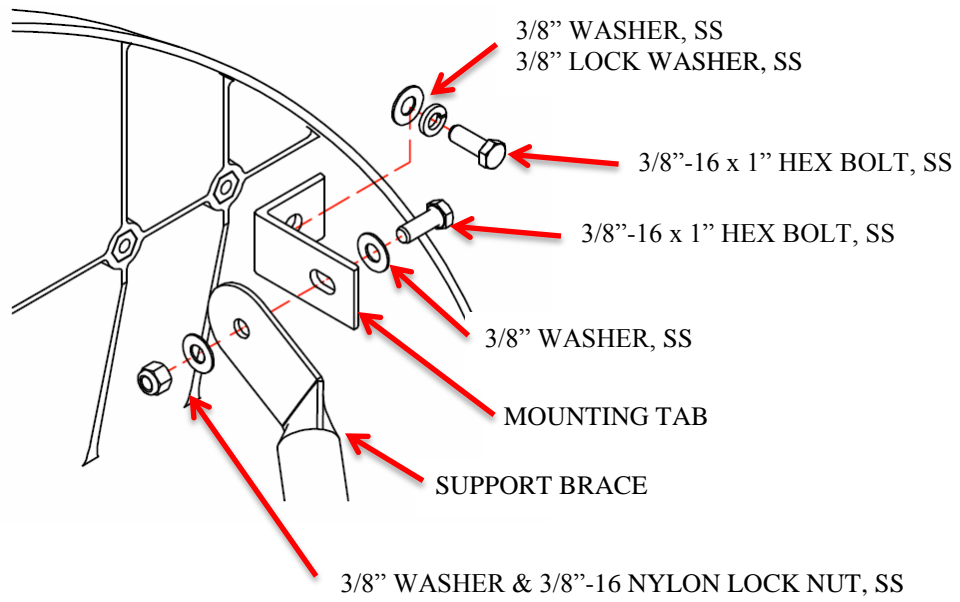


Figure 5

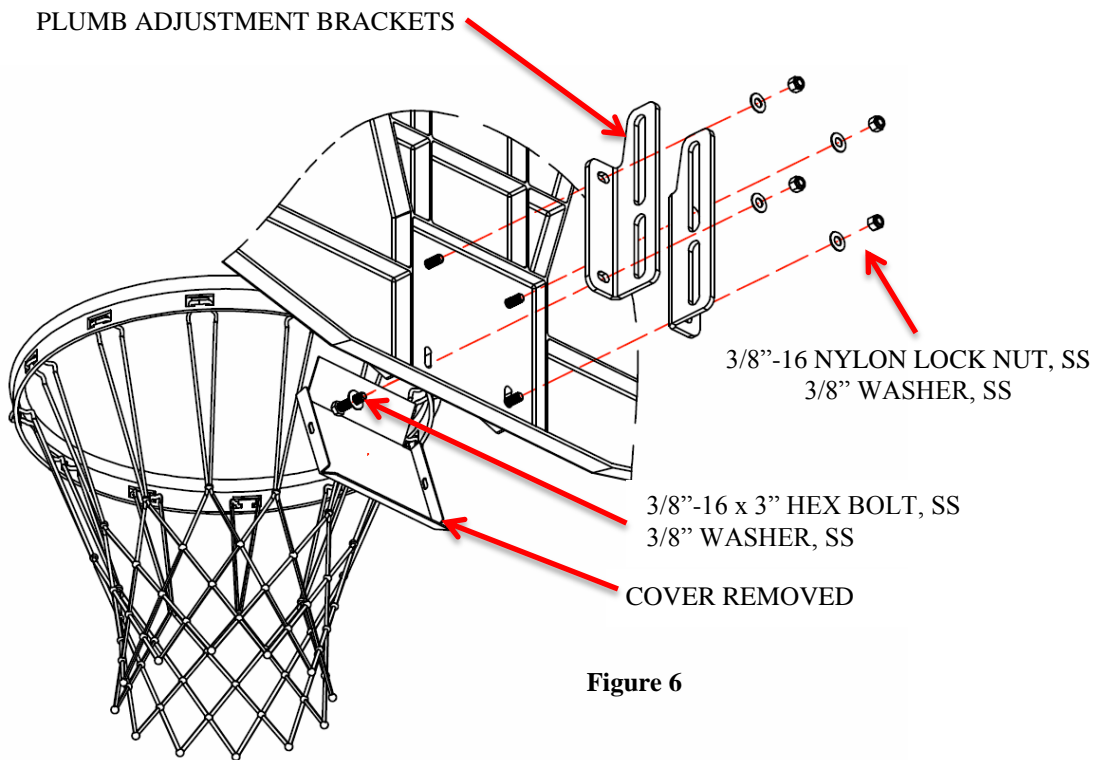


Figure 6

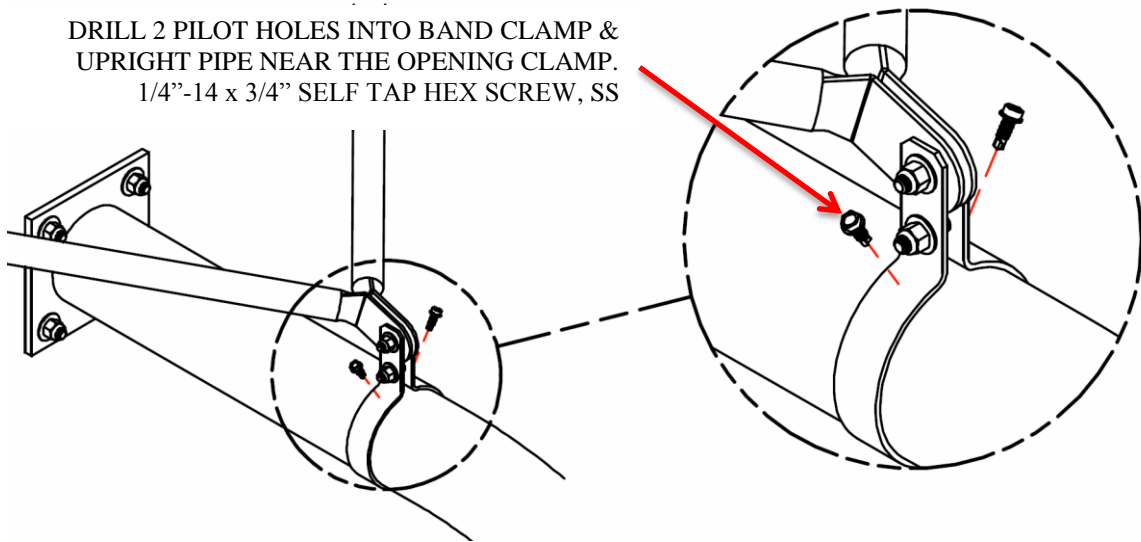
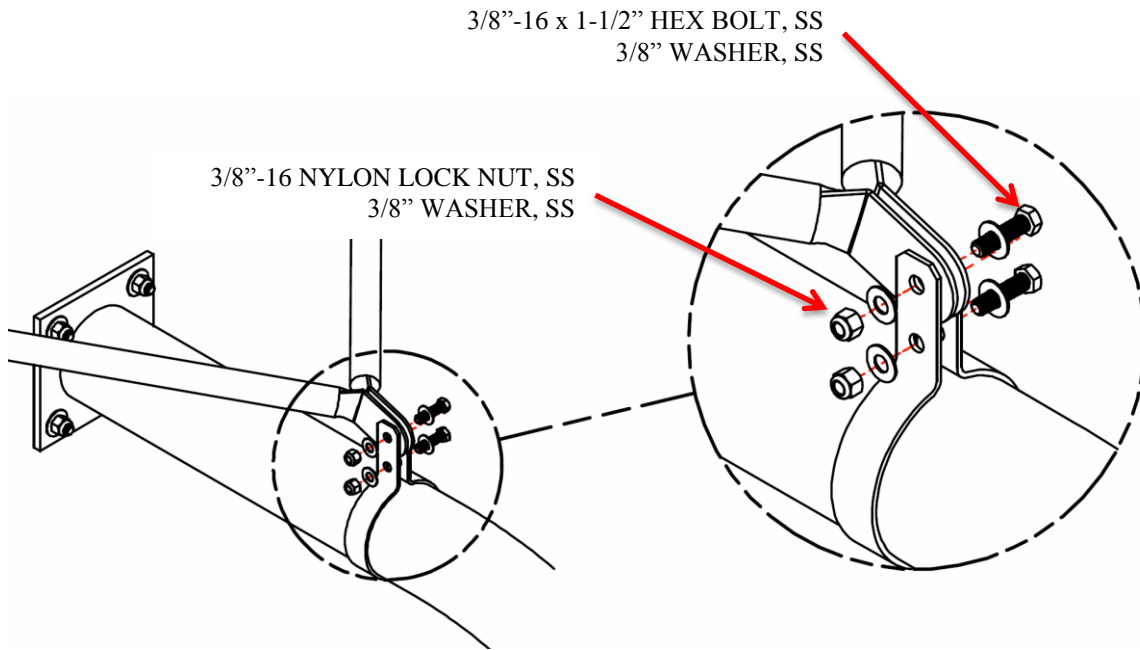


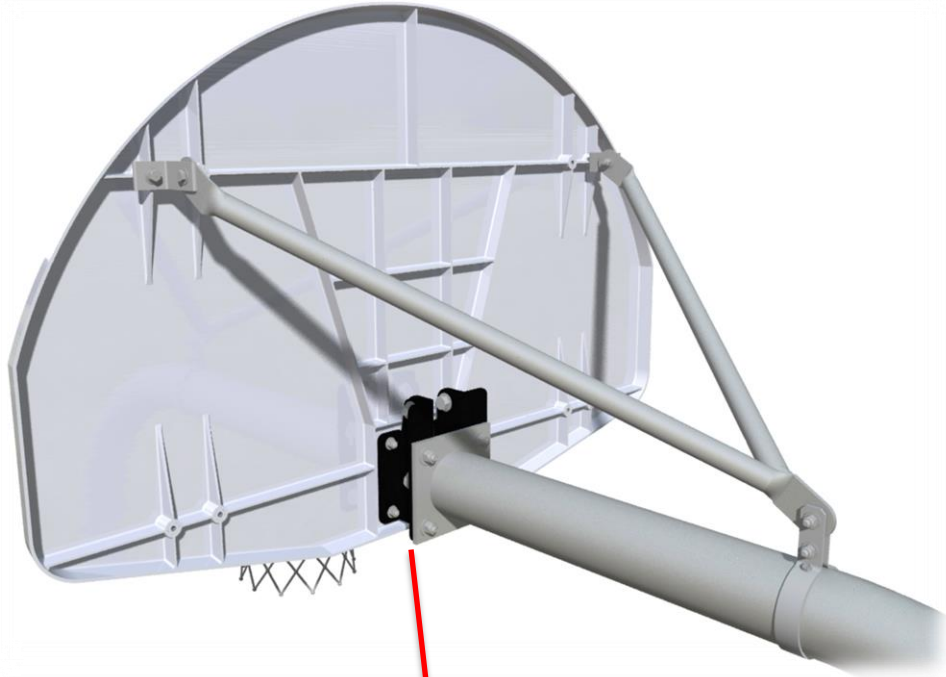
Figure 7

Maintenance:

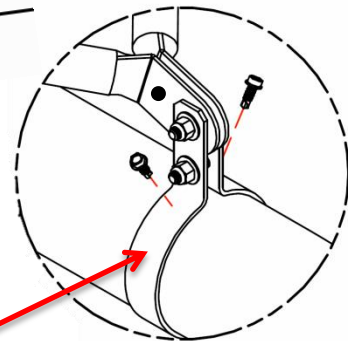
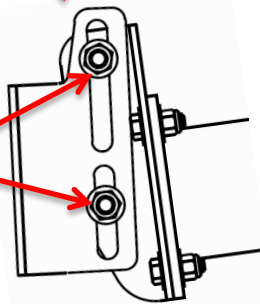
Thoroughly inspect the system at least twice a year check all hardware for tightness and wear.

Inspect the system for any surface rust. Brush off and protect rusted areas with a Rustoleum type zinc spray.

Check the height and plumpness of the system. Carefully adjust if needed.



LOOSEN THESE FOUR BOLTS AND SLIDE THE ENTIRE BACKBOARD UP OR DOWN.



NOTE: BRACING MY NEED TO BE LOOSEN AND RE-APPLY SELF TAP SCREW