

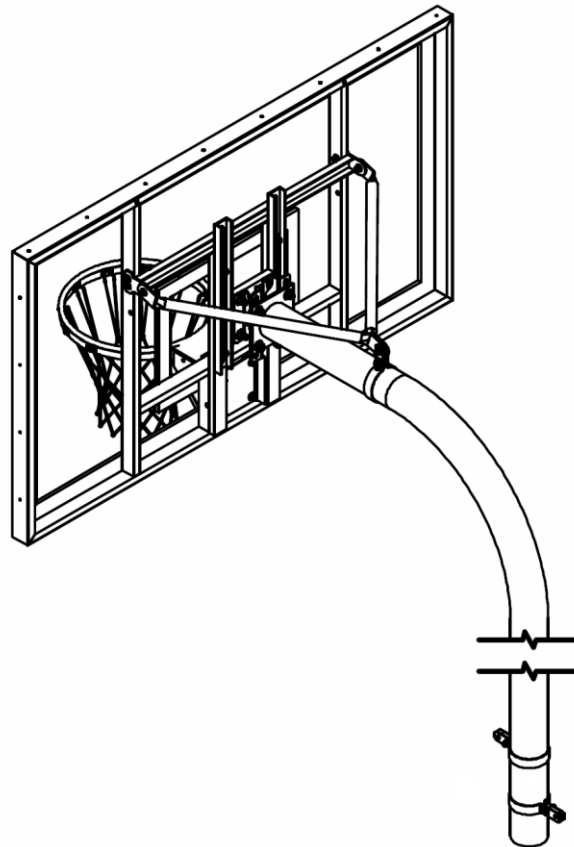

-- HRKIT-AC --
(WITH THE HOOP REJUVENATOR™)
Installation Instructions



Call Jaypro Sports Equipment at 1-800-243-0533
during regular business hours for technical support.

www.jaypro.com

JAYPRO SPORTS
 HRKIT-AC (RECTANGULAR ACRYLIC BACKBOARD)

IMPORTANT NOTICE:

- 1) INSPECT FOR DAMAGE. REPORT ALL DAMAGES TO TRUCKING COMPANY.
- 2) BEFORE EACH USE CHECK EQUIPMENT FOR PROPER CONNECTING HARDWARE AND STRUCTURAL INTEGRITY. REPLACE DAMAGED OR MISSING HARDWARE IMMEDIATELY.
- 3) USE OF THIS EQUIPMENT OTHER THAN INTENDED, MAY BE HAZARDOUS.
- 4) ALTERATION OR MODIFICATION OF THIS EQUIPMENT MAY BE HAZARDOUS AND RESULT IN INJURY. FOR REPAIR OR REPLACEMENT, CONTACT YOUR DEALER OR JAYPRO SPORTS.

PARTS LIST SHOWN FOR ONE UNIT		
IMAGE	QTY	DESCRIPTION
	1	H-FRAME (P/N: HRKIT-AC-A)
	1	T-FRAME (P/N: HRKIT-AC-B)
	2	H-FRAME BOARD BRACKET (P/N: SR5496)
	2	H-FRAME GOOSENECK BRACKET (P/N: SR5495)
	2	SUPPORT BRACE (P/N: HRKIT-AC-1)
IMAGE	QTY	DESCRIPTION

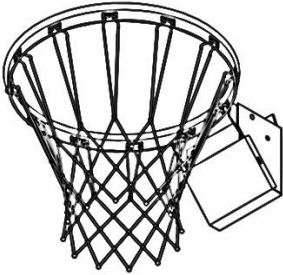
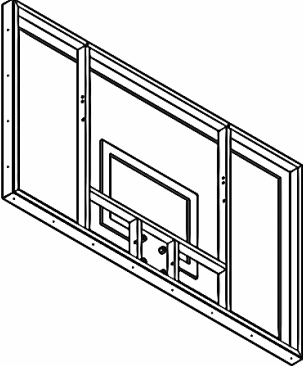
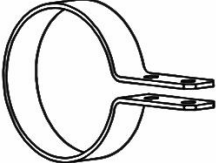
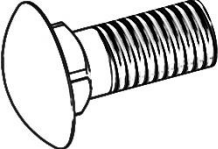





IMAGE	QTY	DESCRIPTION
	1	DOUBLE RIM ULTIMATE BREAKAWAY GOAL (P/N: UBG-500F)
	1	42" x 72" RECTANGULAR ACRYLIC BACKBOARD (P/N: ACRB-72)
	3	4-1/2" OD BAND CLAMP (P/N: BRC45)
	4	1/2"-13 x 1-1/4" CARRIAGE BOLT, SS
	2	3/8"-16 HEX NUT, SS
	24	3/8"-16 NYLON LOCK NUT, ZP
	8	1/2"-13 NYLON LOCK NUT, SS
	4	1/2"-13 HEX NUT, SS
	1	5/8"-11 NYLON LOCKNUT, SS
IMAGE	QTY	DESCRIPTION

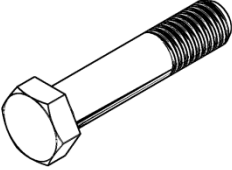
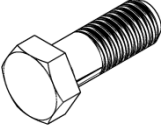
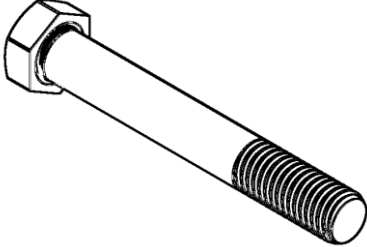
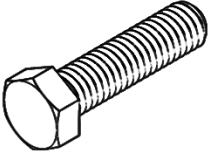
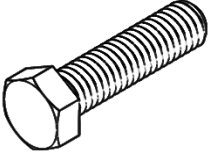
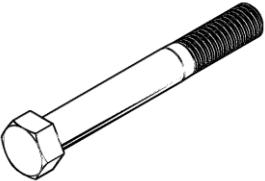



IMAGE	QTY	DESCRIPTION
	4	3/8\"-16 x 1-3/4\" HEX BOLT, SS
	6	3/8\"-16 x 1\" HEX BOLT, SS
	1	5/8\"-11 x 4-1/2\" HEX BOLT, SS
	8	3/8\"-16 x 1-1/4\" HEX BOLT, SS
	2	3/8\"-16 x 1-1/2\" HEX BOLT, SS
	4	3/8\"-16 x 3\" HEX BOLT, SS
	4	1/2\" LOCK WASHER, SS
	4	1/2\" WASHER, SS
IMAGE	QTY	DESCRIPTION

IMAGE	QTY	DESCRIPTION
	48	3/8" WASHER, SS
	2	5/8" WASHER, SS
	2	1/4"-14 x 3/4" SELF TAP HEX SCREW, SS
IMAGE	QTY	DESCRIPTION

TOOLS REQUIRED:

- | | |
|---|-------------------------------|
| (1) 9/16" Socket Wrench and Box Wrench | (1) Anti-seize Compound |
| (1) 3/4" Socket Wrench and Box Wrench | (1) Scaffolding, Lull or Lift |
| (1) 15/16" Socket Wrench and Box Wrench | (1) 10 or 12 FT Step Ladder |
| (1) Level Device | (for final adjustments) |

Important Note:

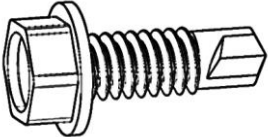
- INSTALLATION OF THE HOOP REJUVENATOR SYSTEM REQUIRES THE LIFTING AND HANDLING OF SUBSTANTIAL WEIGHT, UP TO 270 LBS. SAFE INSTALLATION REQUIRES AT LEAST THREE MEN AND THE USE OF APPROPRIATE MATERIAL HANDLING EQUIPMENT SUCH AS SCAFFOLDING, A LULL OR LIFT.
- **DO NOT ATTEMPT TO ASSEMBLE THE HOOP REJUVENATOR OFF A STEP LADDER.**
- THE HOOP REJUVENATOR OFFERS THE ABILITY TO ADJUST THE HEIGHT OF THE BOARD AND PLUMB IT INDEPENDENTLY. CARE SHOULD BE TAKEN AT EACH STEP TO ENSURE THE FRAMEWORK IS SQUARE AND PLUMB.
- THIS PRODUCT USES STAINLESS STEEL HARDWARE BECAUSE OF ITS SUPERIOR RESISTANCE TO RUST AND CORROSION. STAINLESS NUTS CAN SOMETIME SEIZE ONTO THE BOLT THREADS DURING INSTALLATION OR REMOVAL. TO PREVENT THE STAINLESS HARDWARE FROM SEIZING, LIBERALLY APPLY SOME ANTI-SEIZE COMPOUND TO THE BOLT THREADS, OR SPRAY THE THREADS WITH A PENETRATING LUBRICANT, SUCH AS WD-40.

Upright Assembly:

1. Uninstall the existing backboard and brace that's on the gooseneck.
2. With the can of spray on galvanize, spray any area that is rusted. Allow galvanize to dry before continuing.
3. Attach the H-Frame gooseneck bracket together as shown (*figure 1*).

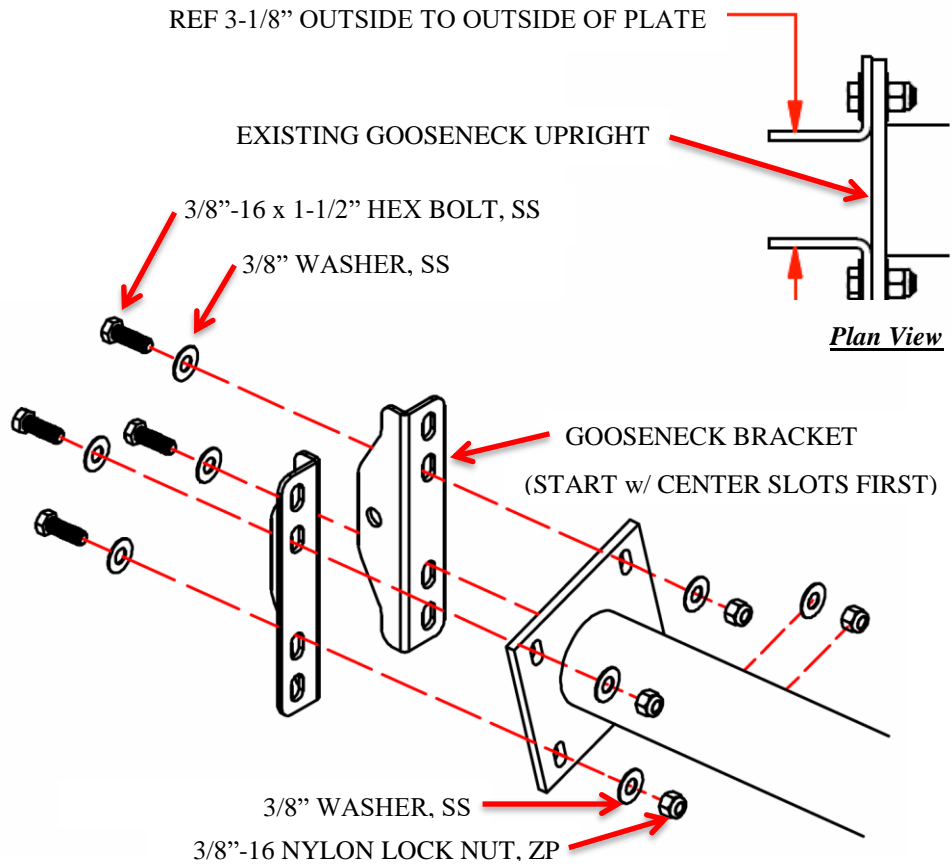

Figure 1

Frame Assembly:

1. Attach the T-Frame to the H-Frame slot channel with 1/2" carriage hardware as shown (Figure 1). Do not tighten.
2. Slide the T-Frame on the H-Frame slot channel till the bottom of both frames are at a distance of 9-7/16" (Figure 2) and tighten the carriage bolts down.
3. Attach H-Frame board bracket to the inner H-Frame slot channel holes. Use 1/2" hex bolt hardware as shown (Figure 3). Set the distance between brackets to be 3-3/8" as shown (Figure 4). Do not tighten hardware.

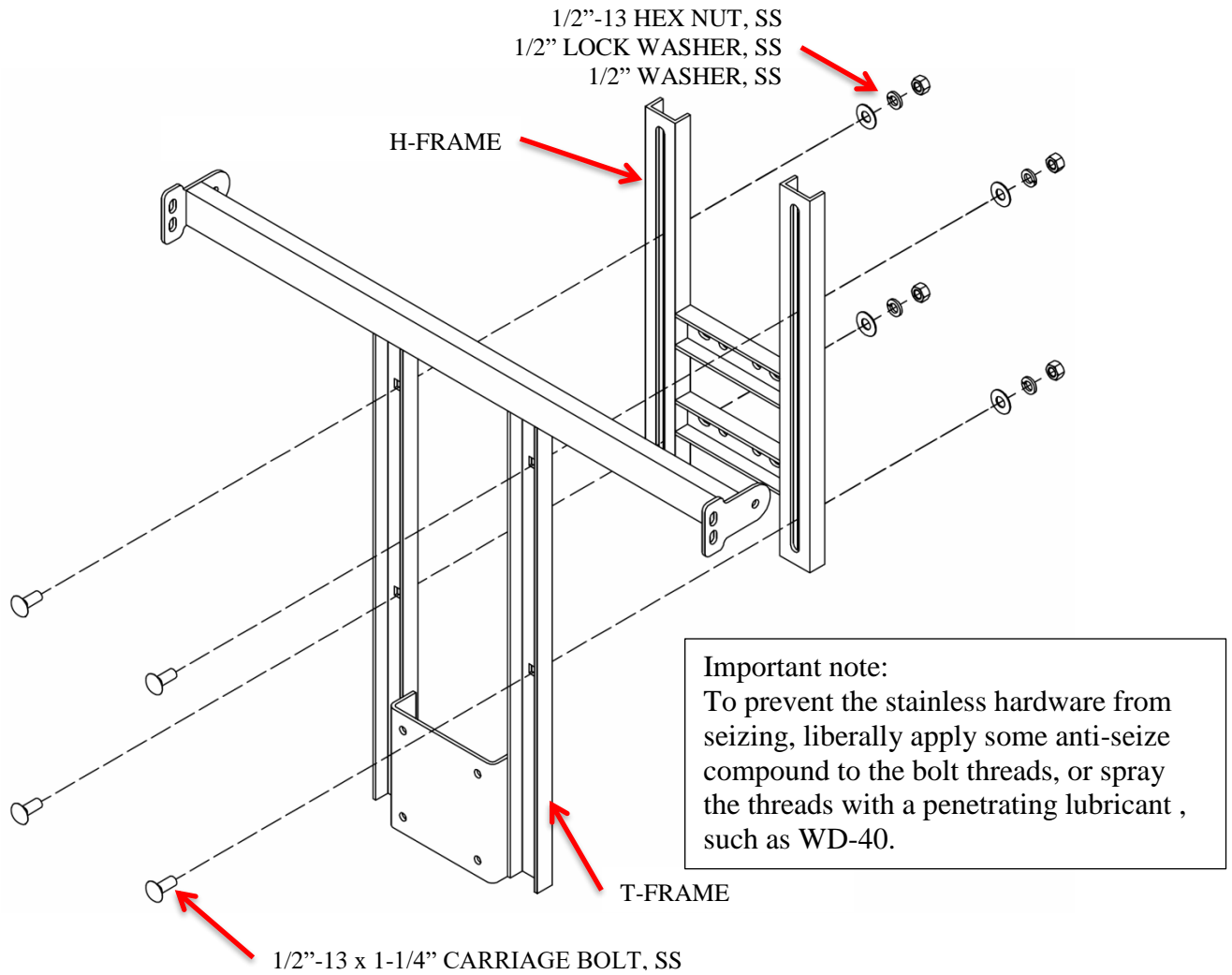

Figure 1

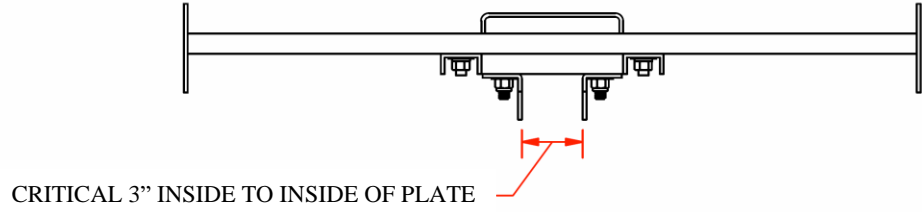

Figure 4

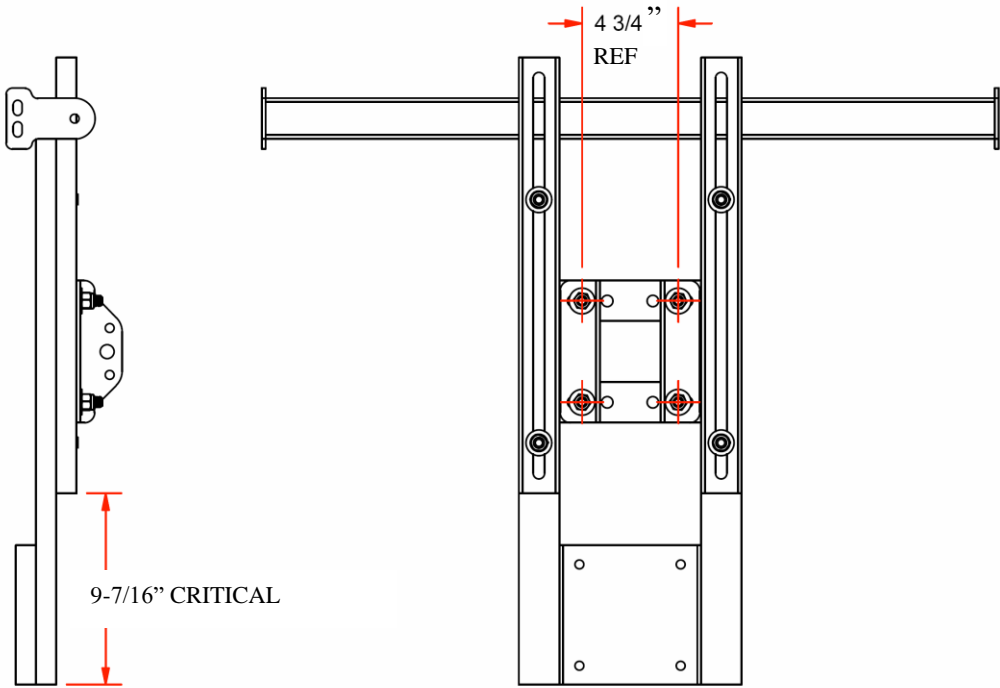

Figure 2

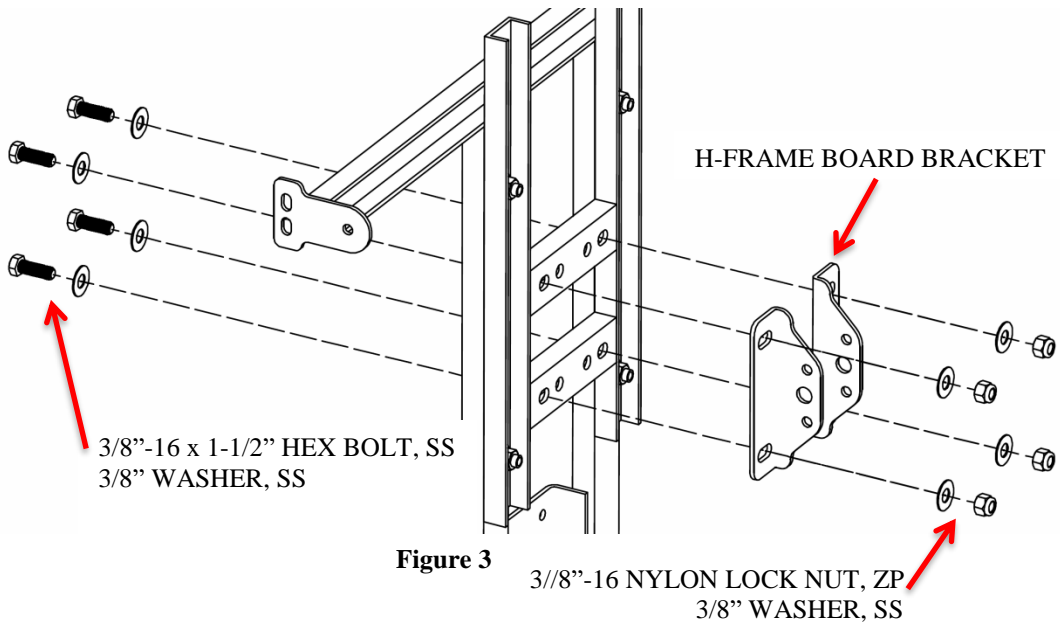

Figure 3

Frame Assembly Attachment:

1. Once the H-Frame board brackets is on the H-Frame gooseneck bracket. Tighten the board bracket hardware (Figure 7).
2. Lift and attach the frame assembly to the mounting plates using 5/8" hardware. Adjust and frame assembly plumb to the playing surface. Do not over tighten.
3. Assemble the two brace as shown (Figure 8). Maintain the plumb while assembling the band clamp to the upright pipe with 3/8" hardware. Lock the plumb in place by drilling 1/4" self-tap hex head screw into two sides of the band clamp & upright pipe as shown (Figure 9).
4. Using the 4 holes in the outer plates as a template to drill thru to the other side of the plate and lock the plumb in place with 4 set of 3/8" hardware as shown (Figure 10).

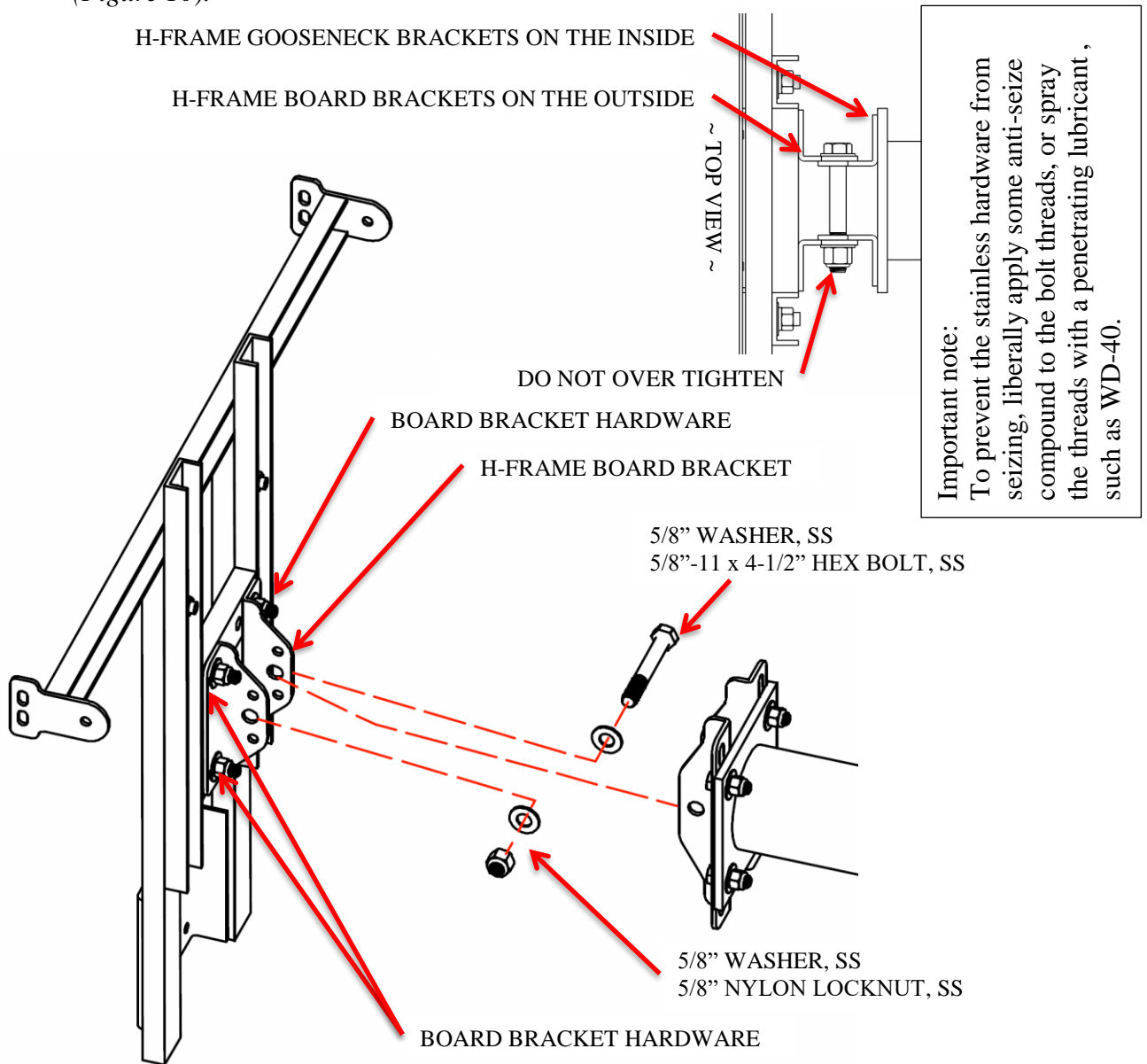

Figure 7

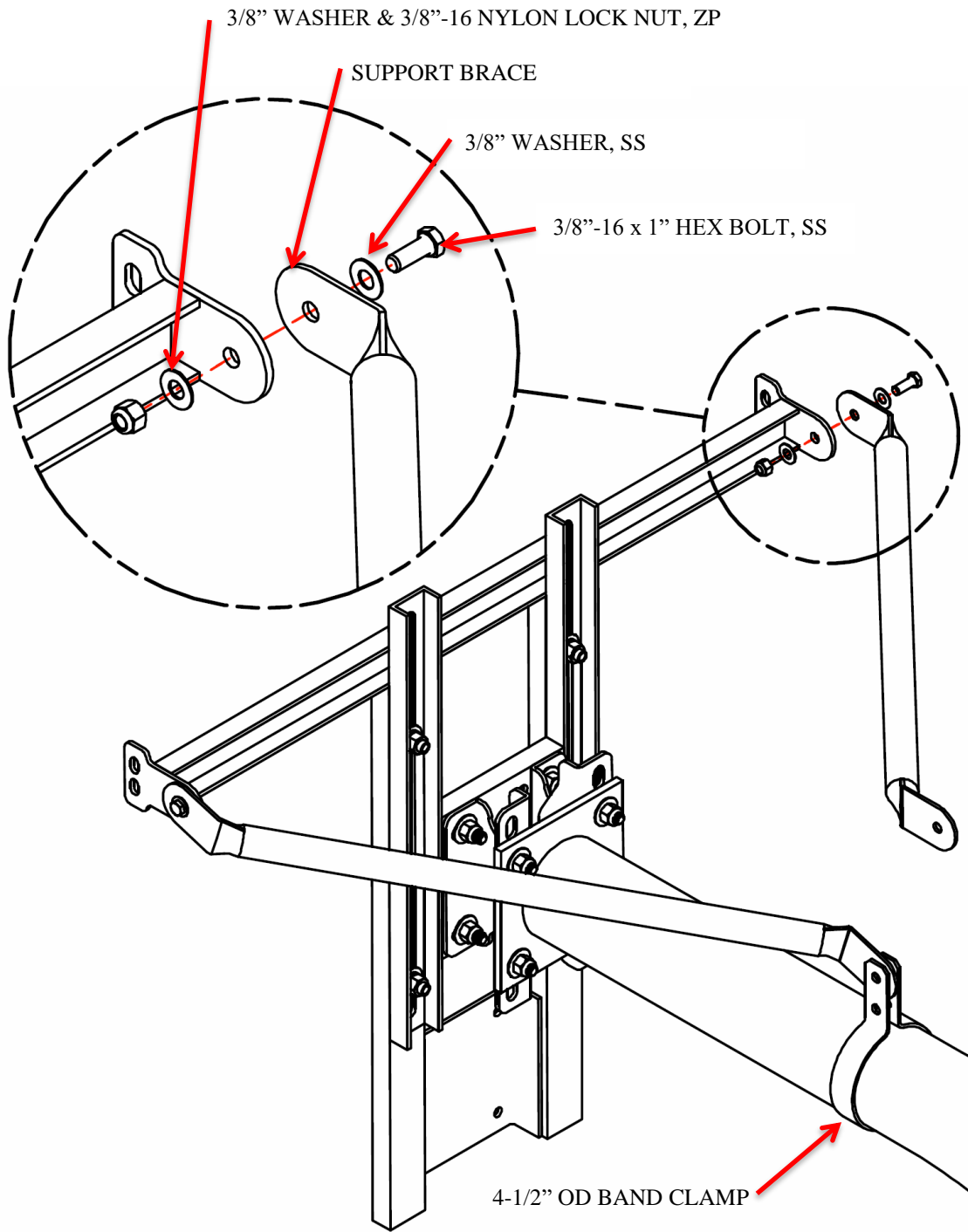

Figure 8

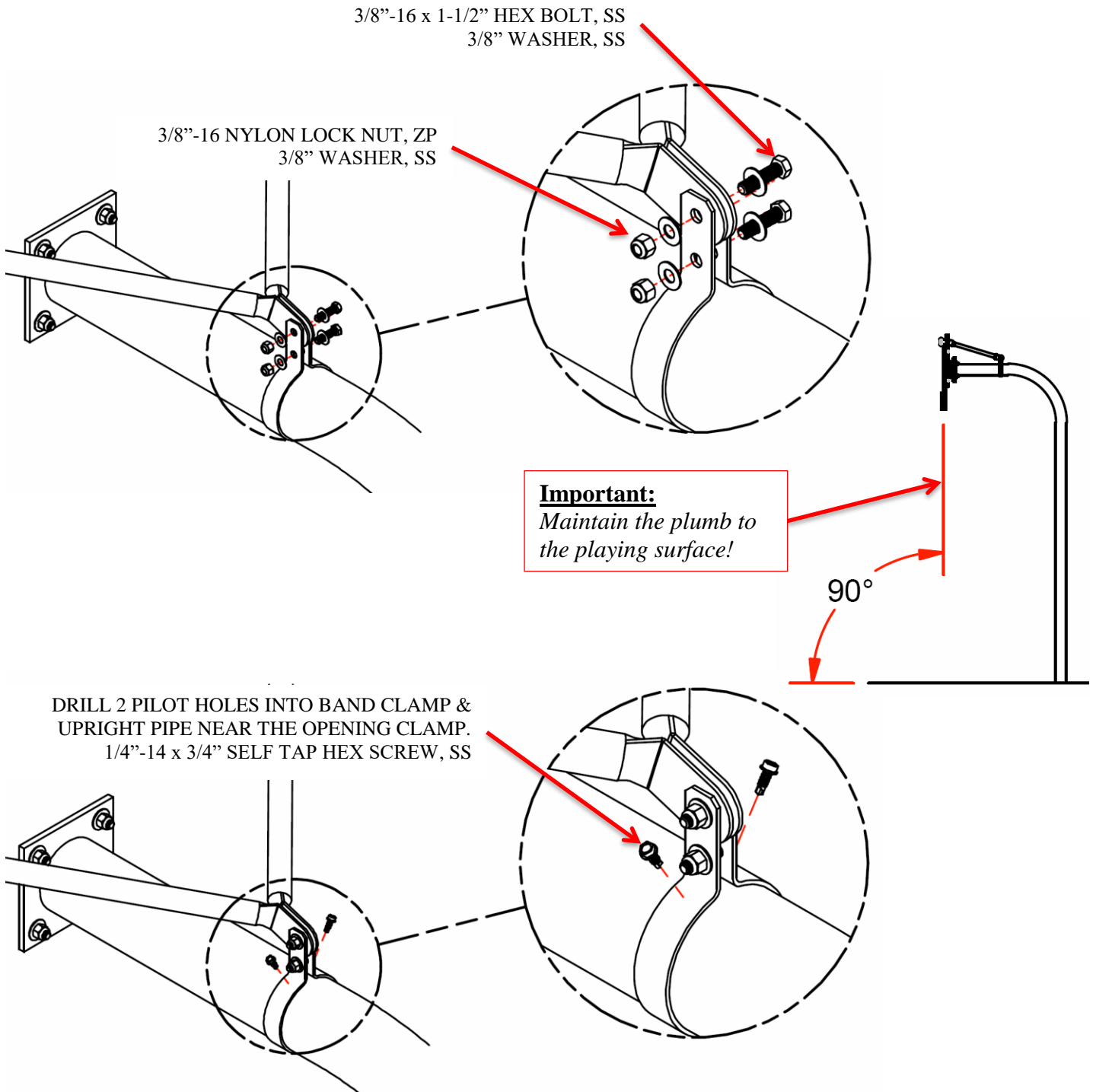
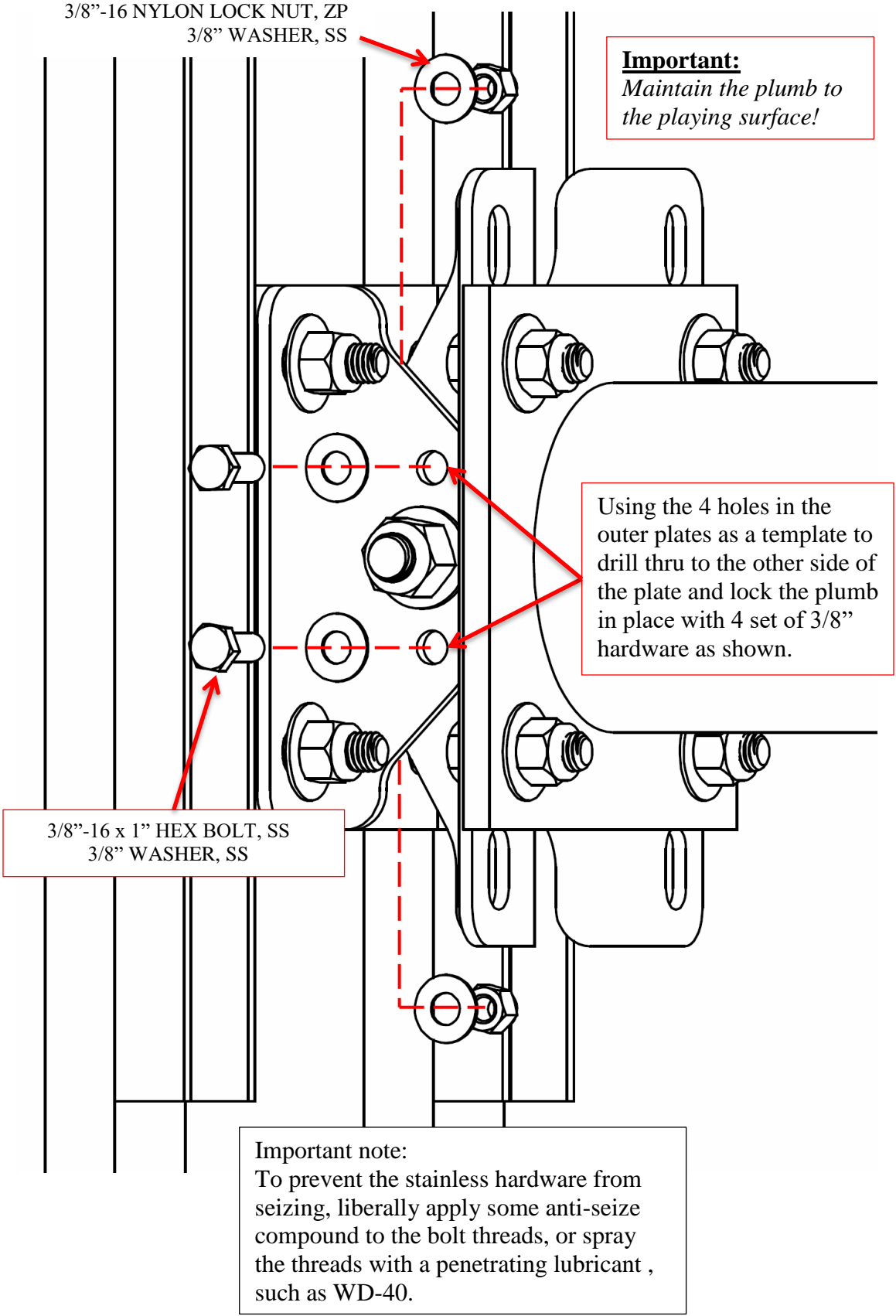
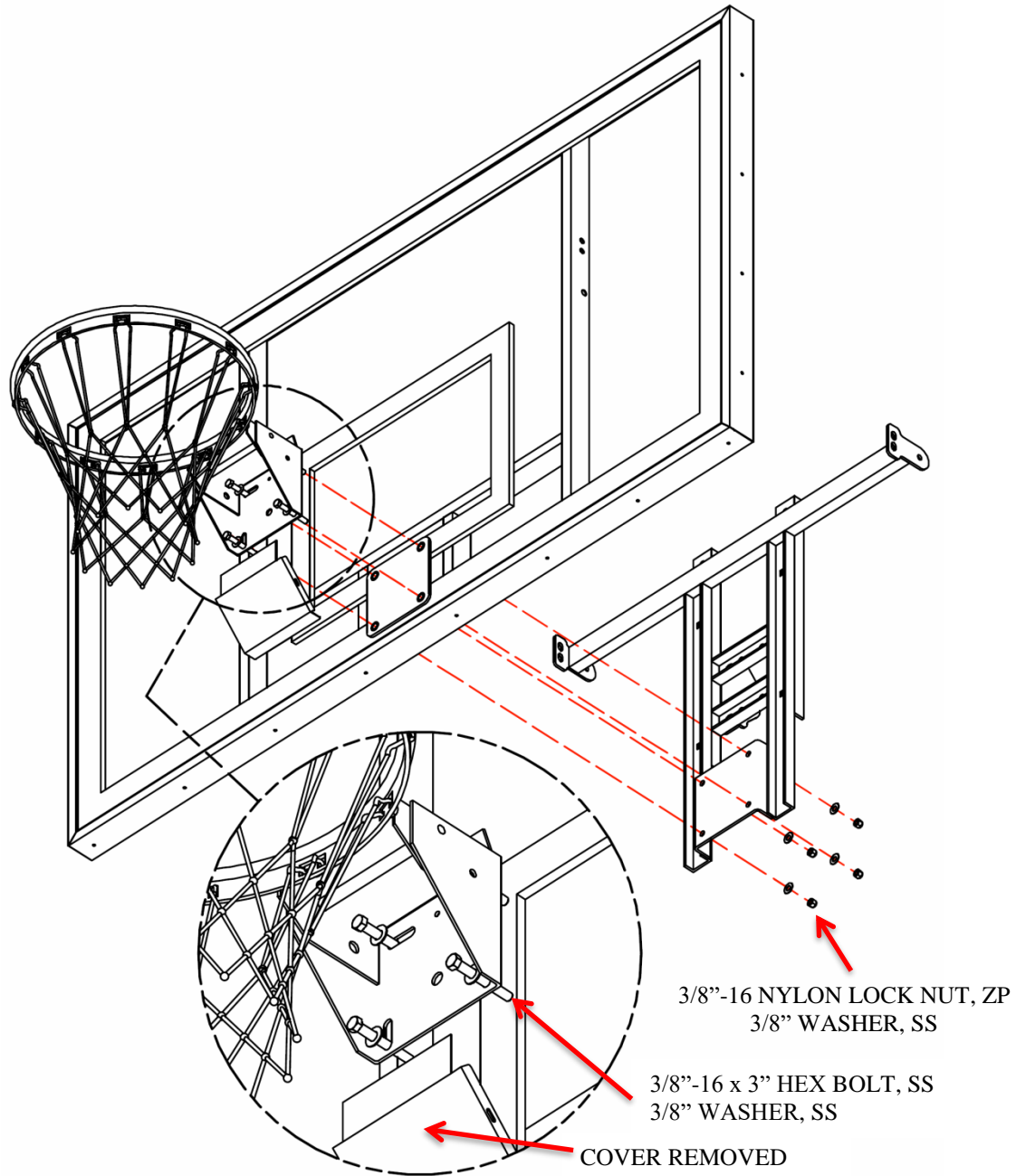

Figure 9



Board Assembly:

1. Attach the appropriate brace mounting bracket to the back of the backboard. The bracket will depend on the backboard ordered. The brackets will either be included with the backboard or board specific in the general kit.



3/8"-16 NYLON LOCK NUT, ZP
3/8" WASHER, SS

3/8" WASHER, SS

3/8"-16 x 1-3/4" HEX BOLT, SS

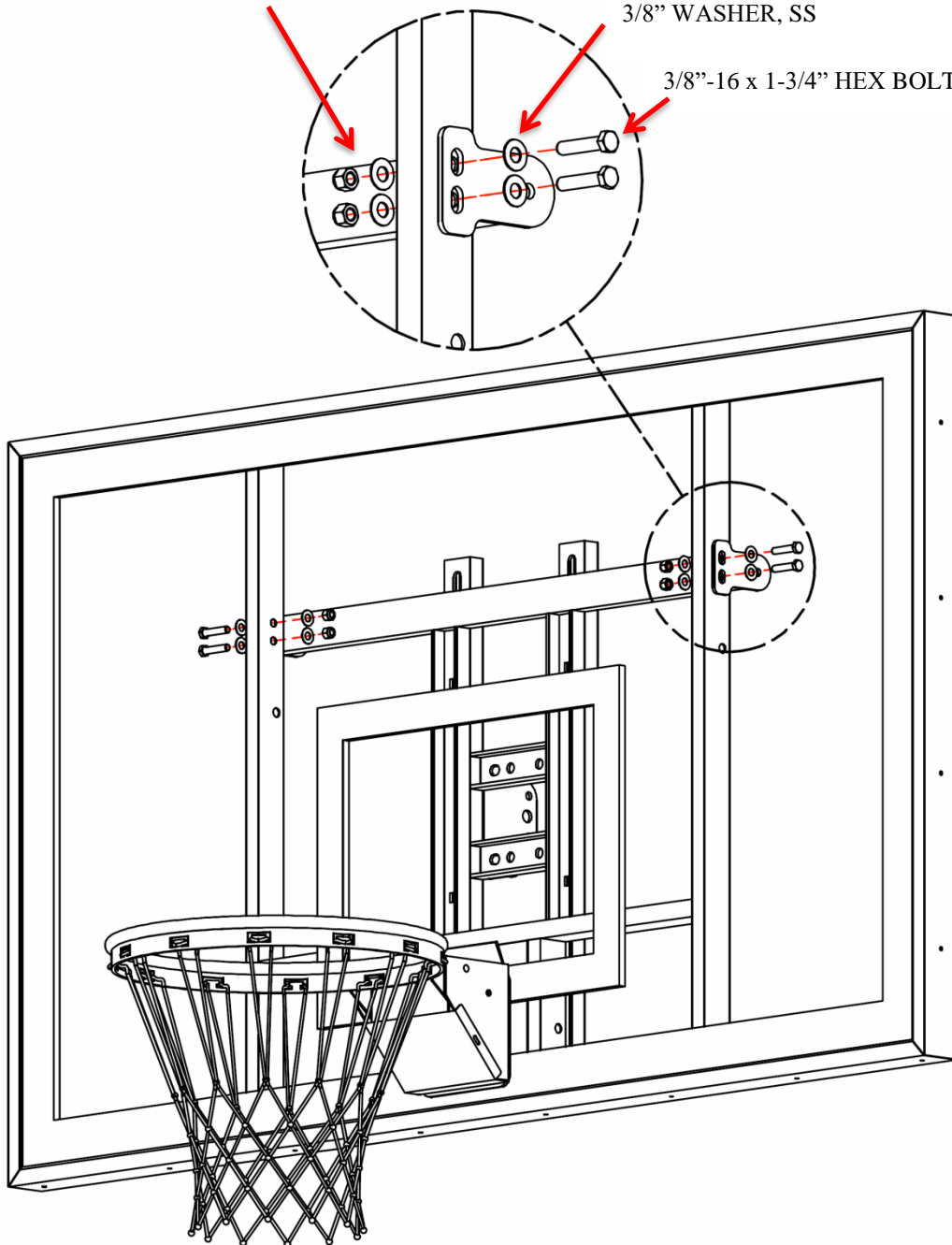

Maintenance:

Thoroughly inspect the system at least twice a year check all hardware for tightness and wear.

Inspect the system for any surface rust. Brush off and protect rusted areas with a Rustoleum type zinc spray.

Check the height and plumpness of the system. Carefully adjust if needed.

LOOSEN THESE FOUR BOLTS AND SLIDE THE ENTIRE BACKBOARD UP OR DOWN.

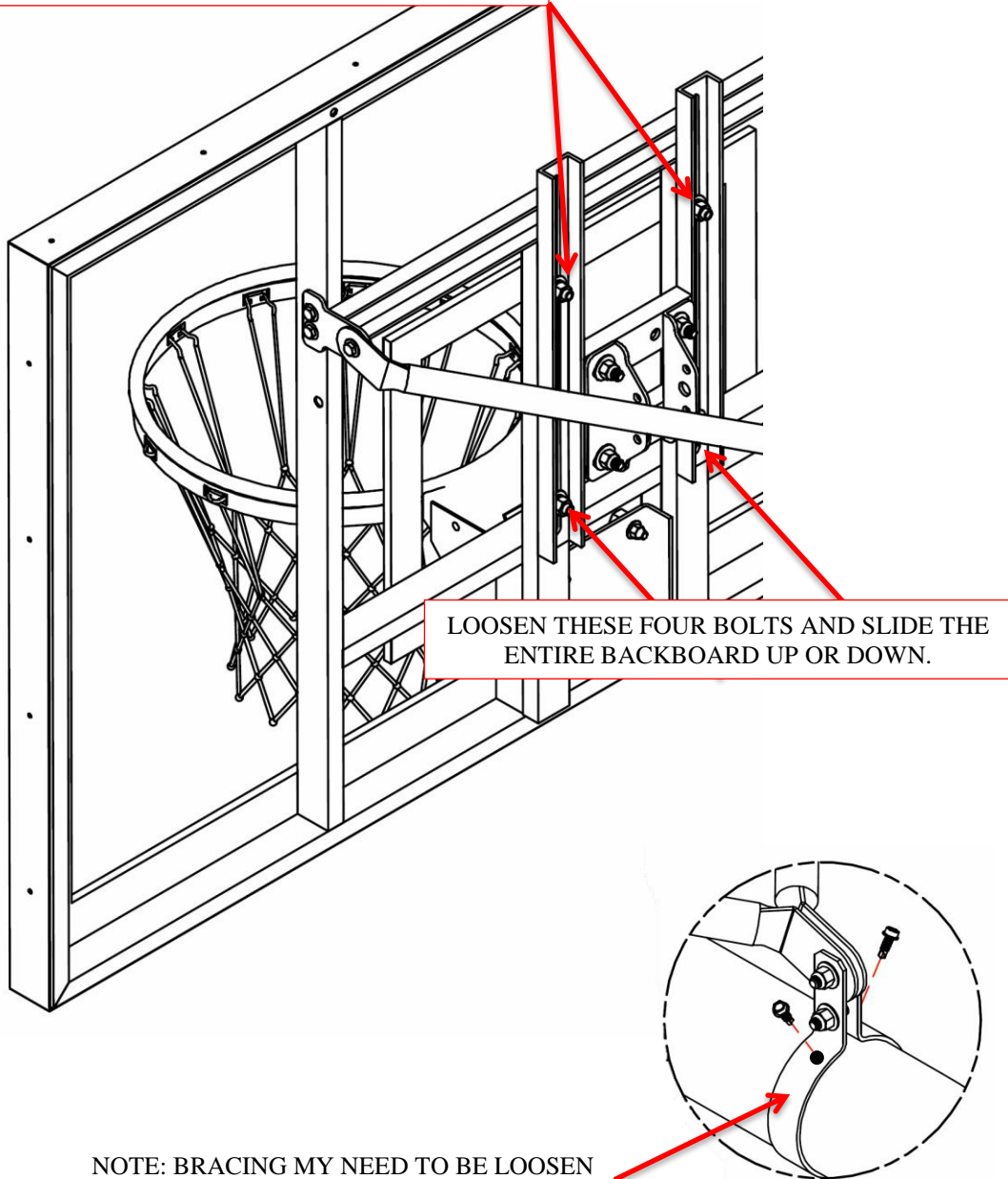

LOOSEN THESE FOUR BOLTS AND SLIDE THE ENTIRE BACKBOARD UP OR DOWN.

NOTE: BRACING MY NEED TO BE LOOSEN AND RE-APPLY SELF TAP SCREW

Important note:
To prevent the stainless hardware from seizing, liberally apply some anti-seize compound to the bolt threads, or spray the threads with a penetrating lubricant , such as WD-40.